

ES-042, ES-044, ES-046 Tantalum Disc Cathodes

FOR USE IN:

- Kimball Physics Electron Sources
- Custom Applications

FEATURES / OPTIONS:

- General Purpose Refractory-Metal Planar Cathode
- Not Harmed by Repeated Exposure to Atmosphere When Cold
- Exceptional Stability
- Low Energy Spread
- Accurately Pre-Aligned
- International Standard AEI Base or Compact CB-104 or CB-105 bases
- Non-Standard Mounting Available

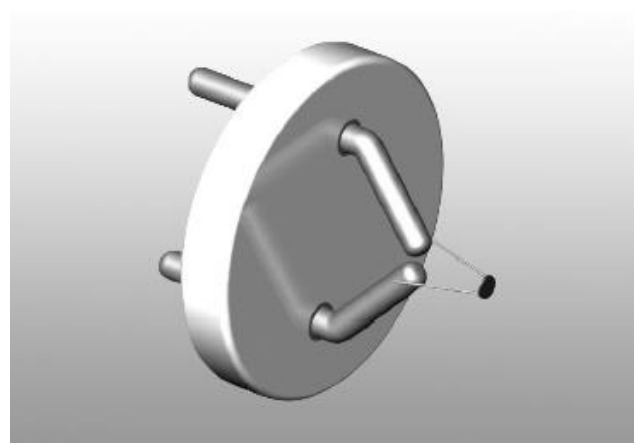

Tantalum Disc Cathode Mounted on a standard AEI base.

The Kimball Physics Tantalum Disc Cathode is a general purpose thermionic emitter. This refractory metal cathode is quite sturdy and provides stable and uniform electron emission for a wide variety of electron source applications. The cathode structure of the ES-042, ES-044, and ES-046 consists of a tantalum disc that is heated by conduction from a tungsten 3% rhenium hairpin and mounted on an industry-standard ceramic AEI base or on a compact Kimball Physics ceramic base. Other bases are available on a custom basis. When ordering a spare cathode or firing unit for use in a Kimball Physics electron gun, simply specify the gun model and options (for example, EMG-12, high current) as this will determine the particular cathode configuration.

The tantalum disc is welded to the tungsten hairpin at a single point, which results in a unipotential and planar emission surface. Since no heating current passes through the tantalum disc, the energy spread is kept to a minimum (<0.7 eV). Tantalum has a very low vapor pressure at high temperatures, a high melting point (3188 K) and a work function of 4.1 eV.

The cathode is not harmed by repeated exposure to atmosphere when cold; however, at temperatures above 700 K, oxidation of both the tantalum and tungsten takes place in the

presence of water vapor, air or oxygen with a resulting decrease in cathode lifetime. At temperatures above 1200 K, tantalum nitrides form in the presence of nitrogen; these compounds degrade the emitting characteristics of the tantalum disc.

Some power is lost from the tantalum disc due to radiation. Therefore, in order to obtain the desired disc temperature, the tungsten hairpin heater must reach an even higher temperature. The temperature of the tantalum disc determines its electron current density; this relationship can be described by the Richardson-Dushman equation.



Tantalum Disc Cathode Mounted on a CB-104 base.

Actual emission currents will vary depending on the applied DC voltage and the geometry of the gun structure. The higher temperatures in the tungsten hairpin leg results in the decrease in harpin leg diameter due to evaporation, and is a determining factor in cathode lifetime (assuming lifetime is not foreshortened due to other factors such as contamination, poor vacuum or damage). As the tungsten legs evaporate, the resistance of the tungsten wire increases; thus even small changes in a cathode's V-I characteristic over its lifetime can be expected. The longest possible lifetime is achieved by running the cathode at the lowest possible temperature.

There are several factors to consider in choosing a cathode size. A larger disc has a larger emission area, and thus more total current for a given current density. The current density of course is a monotonically increasing function of temperature. However, a larger disc loses more power to radiation, and thus more heating power is required. A smaller disc tends to have a more uniform temperature distribution, which results in a more uniform emission. Larger discs with larger legs tend to have a longer lifetime. Kimball Physics has determined several combinations of cathode dimensions that have proved to work well in the Kimball Physics electron guns. The model ES-042 consists of a

0.033 inch (0.84 mm) diameter tantalum disc, attached to a 0.003 inch (0.08 mm) diameter tungsten 3% rhenium heater wire. The higher current models, ES-044 and ES-046 have larger discs and thicker heater wires (see specifications table).

Custom cathodes are available with different refractory metals, optional emitter styles (disc, hairpin, or ribbon), various disc sizes, and various filament lengths and diameters. All models of the tantalum disc cathode structure are available mounted on an industry-standard ceramic AEI base, or on a Kimball Physics ceramic base (CB-104 or CB-105), as well as on custom or nonstandard bases.

Base options include two or four pins, pins made of molybdenum or Kovar, various pin lengths and positions, as well as different mounting heights of the cathode surface from the ceramic base. The edge of an AEI base can be ground to a specified custom diameter. Some combinations of various options may not be possible due to design considerations. All cathodes are shipped vacuum clean and ready to install.

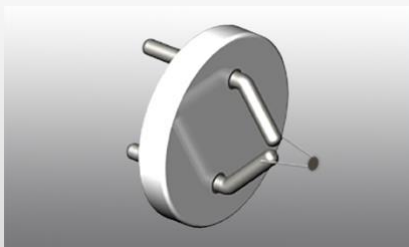

Tantalum Disc Cathode ES-042 mounted on a AEI base.



Tantalum Disc Cathode ES-042 mounted on a CB-104 base.

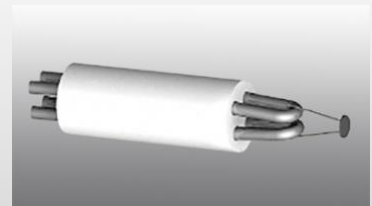

Tantalum Disc Cathode ES-044 mounted on a CB-105 base.

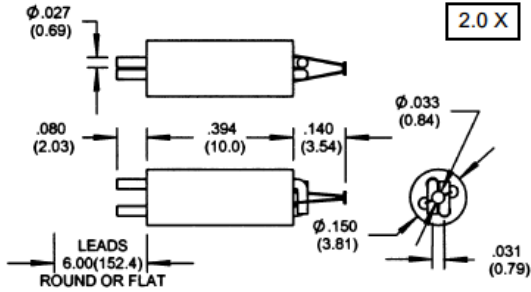

ES-042 Tantalum Disc Cathode
mounted on a CB-104 ceramic base

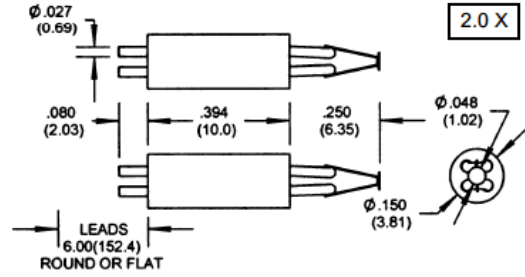

ES-044 Tantalum Disc Cathode
mounted on a high current CB-105 ceramic base

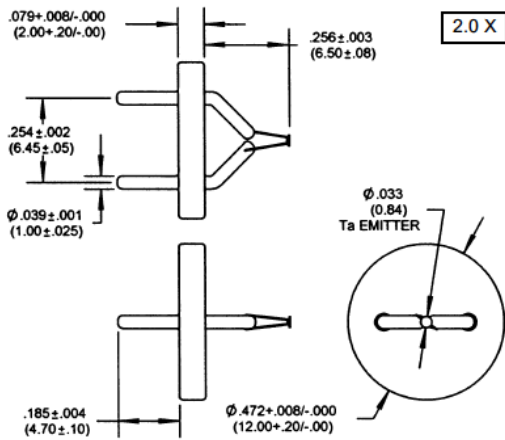

ES-042 Tantalum Disc Cathode mounted on an AEI ceramic base
ES-044 and ES-046 also available on AEI bases

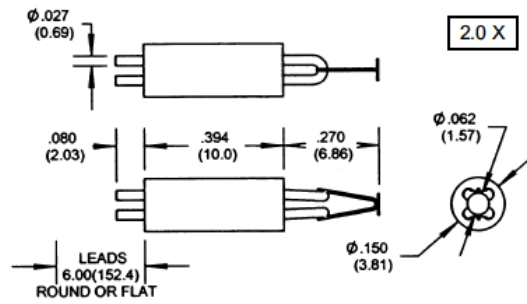

ES-046 Tantalum Disc Cathode
mounted on a high current CB-105 ceramic base

-ALL DIMENSIONS ARE IN INCHES. (MILLIMETERS IN PARENTHESES)
-MAGNIFICATIONS ARE APPROXIMATE (TO PROVIDE SIZE ESTIMATE)

Tantalum Cathode Comparison Table

Parameter	ES-042	ES-044	ES-046
CATHODE MATERIAL	Tantalum	Tantalum	Tantalum
DISC SIZE	0.033 in dia. x .004 in thick (0.84 mm dia. x 0.1 mm thick)	0.048 in dia. x .004 in thick (1.22 mm dia. x 0.1 mm thick)	0.062 in dia. x .004 in thick (1.57 mm dia. x 0.1 mm thick)
HEATER WIRE SIZE	0.003 in dia. (0.08 mm dia.)	0.004 in dia. (0.1 mm dia.)	0.007 in dia. (0.18 mm dia.)
LEG LENGTH	approx. 0.11 in (2.8 mm)	approx. 0.12 in (2.8 mm)	approx. 0.15 in (3.8 mm)
HEIGHT ABOVE CERAMIC BASE	on CB-104 base: 0.14 in (3.5 mm) on AEI base: 0.256 in (6.5 mm)	on CB-105 base: 0.25 in (6.4 mm) on AEI base: 0.256 in (6.5 mm)	on CB-105 base: 0.27 in (6.9 mm) on AEI base: 0.256 in (6.5 mm)
EMISSION AREA	$5.52 \times 10^{-3} \text{ cm}^2$	$11.7 \times 10^{-3} \text{ cm}^2$	$19.5 \times 10^{-3} \text{ cm}^2$
EMISSION CURRENT	1 mA typical	3 mA typical	5 mA typical
HEATING CURRENT	1.4 A to 1.8 A	2.4 A to 2.8 A	5.7 A to 6.6 A
POWER SUPPLY CAPABILITY	Voltage regulated power supply recommended, 2 V, 2 A	Voltage regulated power supply recommended, 2 V, 3 A	Voltage regulated power supply recommended, 2 V, 7 A
CATHODE BASES	AEI, CB-104	AEI, CB-105	AEI, CB-105
CATHODE LOADING	0.25 A/cm ² recommended, typical; High loadings result in reduced lifetime		
WORK FUNCTION	4.1 eV		
OPERATING TEMP	2200 K typical		
ENERGY SPREAD	Approx. 0.6 eV		
LIFETIME	Hundreds of hours with medium current		
VACUUM LEVEL	10^{-5} torr or better, recommended		

References

For more information on cathodes operations, you may download additional detailed technical bulletins (not listed below) from our website Resources Page.

Cathodes- Emitters (Overview)

Tantalum (Ta) Cathodes / Emitters- Description and Specifications (Overview)

Ta Disc Cathode (ES-042) - Cathodes / Emitters: User Information

Ta Disc Cathode (ES-044) - Cathodes / Emitters: User Information

Ta Disc Cathode (ES-046) - Cathodes / Emitters- User Information

Notes:

1. Charts /graphs show typical performance, data is for guidance only
2. It is not necessarily possible to achieve all maximum specifications simultaneously.
3. Specifications Subject to Change Without Notice.
4. DE Altobelli, DT Taylor 2/09/2023

Document: Tantalum Cathodes_2023_0209
COPYRIGHT KIMBALL PHYSICS 2023, ALL RIGHTS RESERVED