

Faraday Cup FC-86: Stand-Alone, Water-Cooled Faraday Cup Assembly

APPLICATIONS:

- Continuous Collection and Measurement of Charged Particle Current
- Measurement of Emitted Beam for Electron or Ion Gun

FEATURES / OPTIONS:

- Shielded Faraday Cup Assembly
- Water Cooled
- Measure Electron or Ion Beams up to 1245 watts
- Removable Phosphor Screen permits visual, real-time observation of spot
- Optional 2-degree Port Aligner for Mechanical Alignment is available



Faraday Cup FC-86

INTRODUCTION

The Kimball Physics FC-86 Faraday Cup Assembly is a complete water-cooled, shielded Faraday cup assembly mounted on a 2.75" CF Flange Multiplexer and ready to attach to the vacuum chamber. The Faraday cup is capable of measuring electron or ion beams of up to 1250 watts of beam power. Concentrated beam inputs may have higher local power densities. When possible, have high power beams diverge into the entrance aperture. The removable phosphor screen, positioned around the limiting aperture permits visual, real-time observation of the spot. The phosphor screen and limiting aperture are electrically isolated from ground and, if desired, can be biased with an external power supply. The standard size of the limiting aperture in the phosphor screen is 1 mm diameter; other aperture sizes are available. The maximum

bake-out temperature is 150°C as limited by the phosphor screen, or 350°C with the phosphor screen removed.

The Faraday cup assembly is completely enclosed in a ground shield. An optional 2-degree port aligner for mechanical alignment is available.

Warnings:

- 1) BNC's must be terminated during operation,**
- 2) Water cooling must be electrically isolated using flexible PVC tubing provided**
- 3) High Voltage Hazard**

Please reach out to Kimball Physics to engage our specialists if you need a custom system for your specific application.

Faraday Cup FC-86	
APERTURE SIZE	1 mm diameter standard (Custom Available)
INPUT POWER CONTINUOUS	1250 Watts maximum
INSERTION LENGTH	5.6" (without optional 2-degree port aligner)
MOUNTING	2.75" CF Flange
OPERATING TEMPERATURE	150°C Maximum with Phosphor Screen
BAKEOUT TEMPERATURE	350°C Maximum with Phosphor Screen and cables REMOVED

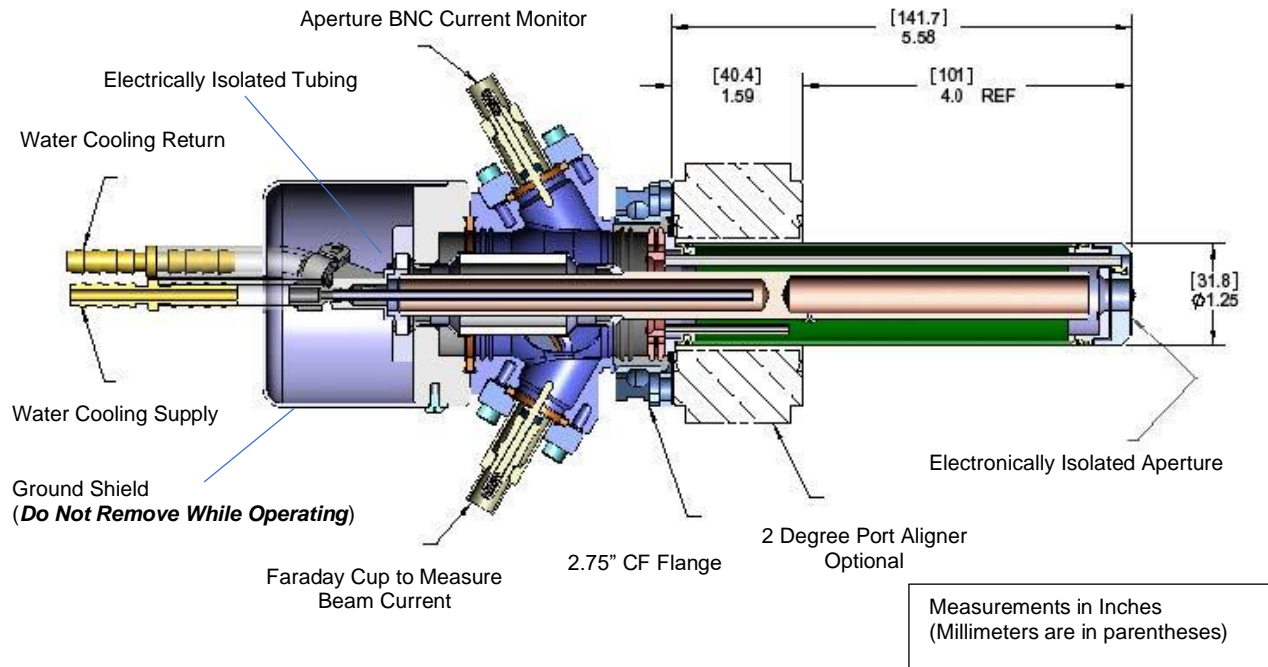

Solid Model in cross-section of Faraday Cup Detector FC-66.

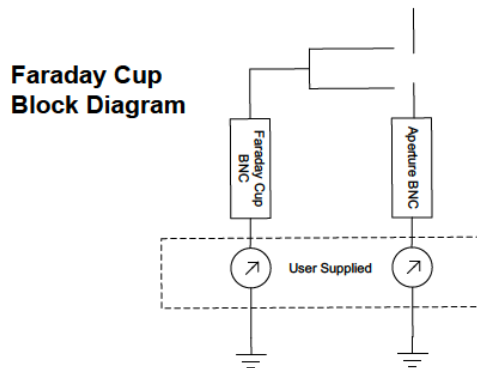

Faraday Cup block diagram showing ways to bias Faraday Cup and Aperture in FC-66.

References

For more information about Kimball Physics Detectors, please visit our website:
[Kimball Physics Detectors](http://www.kimballphysics.com)

Notes:

1. **Cautions:**

- Silver Plated Bolts or Equivalent Lubrication must be used
- Please measure the hole depth and other flange / copper ring / part thicknesses
- Choose a correct bolt length such that the bolt doesn't bottom in the tapped hole prior to tightening the structure

2. Specifications Subject to Change Without Notice.

3. DE Altobelli, DT Taylor 01/18/2023

Document Detector_Faraday_Cup_FC-86_2023_0118

COPYRIGHT KIMBALL PHYSICS 2023, ALL RIGHTS RESERVED