

4.9 BEAM BLANKING AND PULSING OPTIONS

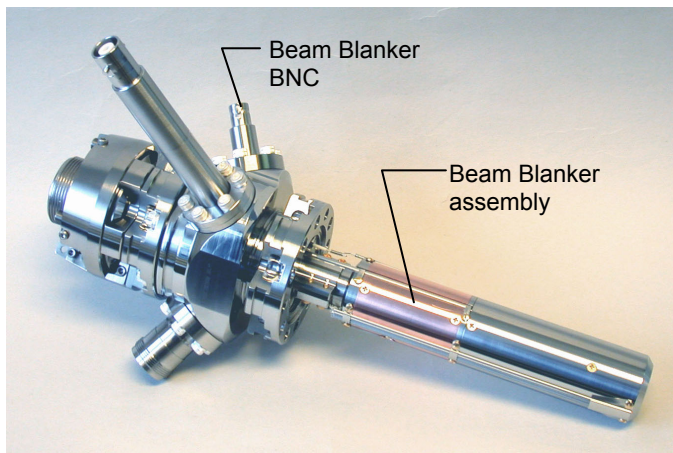

Fig. 4.9-1 A typical electron gun with an optional Beam Blanker (copper section)

The beam blanking and pulsing option requires a blanker plate assembly built into the Electron Gun and an additional blanker supply unit in the main Power Supply. Beam blanking deflects the electron beam into a beam trap on the side of the gun tube, so that the flow of electrons to the target is interrupted without actually turning off the beam. A sufficiently large negative voltage on the plate opposite the angled plates will push the electrons into the trap. The deflecting voltage applied to the blanker in the gun is controlled on the EGPS Power Supply. The blanker voltage required to blank the beam depends on the gun configuration and on the beam energy. Blanking is useful for guns which can not be cut off by means of the grid due to high current or gun geometry.

Blanking can be used to pulse the final beam current repeatedly on and off. Unlike other types of pulsing, beam blanking can be used with ECC (emission current control) as blanking does not affect emission from the cathode.

There are two different methods of pulsing with the beam blanker: **1) TTL switched pulsing** and **2) capacitive pulsing** with a pulse junction box. The first method is slower as the blanker power supply is switched off and on in response to a TTL signal input. A TTL (transistor-transistor logic) pulse source is required, such as a separate user-supplied pulse generator unit. The second method, capacitive pulsing, can be faster, but long pulses are not achievable. It requires a small pulse junction box attached to the electron gun and a separate user-supplied pulse generator capable of producing positive voltages (usually up to +600 V) at the desired rate. (The same pulse generator can also be used for capacitive pulsing with a pulse junction cylinder, section 4.8.2 above)

DESCRIPTION OF BLANKER CONTROLS

Electron Gun Controls

Blanker BNC: An input BNC on one of the 1½ CF flanges on the Flange Multiplexer on the Electron Gun that connects the input from the Power Supply to the blanker plates inside the gun.

EGPS Power Supply Controls

Blanker Control / Meter: A FlexPanel control on the front display panel labeled **BLANKER** that is used in conjunction with a TTL signal input to blank-off (stop) or pulse the beam. When selected, the encoder wheel voltage programs the Blanker power supply. Alternatively, computer controls through the RS-232 port or analog external interface can voltage program the Blanker supply. (Standard range: 0 to +600 V)

Blanker input BNC: A BNC on the back panel labeled **TTL IN** to receive a 0 to +5 VDC TTL signal from a user-supplied TTL pulse generator for beam blanking. The TTL signal input controls the Blanker supply and can be used to pulse the beam off and on. A zero volt signal enable the blanker to stop the electron beam. When the BNC is unterminated, an internal pull-up resistor (+5 V signal) controls the Blanker supply, allowing the beam to be on.

Blanker Output: An output BNC, labeled **BLANKER OUT** on the back panel of the Power Supply that provides the output voltage of the Blanker power supply, connects with the BNC connector on the electron gun via a 50 ohm (RG-58) coaxial cable.

Optional LabVIEW™ Program Controls

Blanker On/Off switch: A toggle switch labeled **Blanker On / Off**. When **On**, the blanker supply is voltage programmed by the Blanker control. When **Off**, a programming voltage of 0 V is sent to the blanker supply, regardless of the voltage control setting or the TTL input, so that the blanker output will be 0 V and the beam can be on.

Blanker Control / Meter: A digital program input control that voltage programs the Blanker power supply in the same way as the front panel control. The associated **Fine/Coarse** slide switch changes the input increments controlled by the up/down arrow switches by a factor of ten.

4.9 BEAM BLANKING AND PULSING OPTIONS cont.

4.9.1 MANUAL OPERATION OF BEAM BLANKER (NON-PULSING)

CAUTION

The blanker BNC on the electron gun must always be connected to the blanker power supply via its coaxial cable.

For gun start up or DC operation, the Blanker voltage must be set to 0 V.

1. Set up:
 - a. Connect the Blanker coaxial cable between the **BLANKER OUT** BNC on the EGPS Power Supply and the Blanker BNC on the electron gun.
CAUTION: The gun BNC must always be connected to the power supply or else shorted to ground, even if blanking is not being used. This is necessary to prevent the blanker plates inside the electron gun from charging up during normal operation.
 - b. For manual blanking, the **TTL IN** BNC on the back of the EGPS must be covered with a shorting BNC connector or a 50 Ω terminator to enable blanking.
 - c. A Pulse Junction Box may be connected to the Blanker BNC on the gun, but the pulse generator should be off.
 - d. (Optional) Monitor the beam current using a Faraday cup at the end of the gun
2. For start up:
 - a. Follow the Normal Start Up Procedure, Section 4.2. or 4.3 to begin gun operation.
CAUTION: For initial start-up, the blanker voltage must be 0 V. If the Blanker is on, the beam will be blanked-off even if the cathode is on. This could cause the user to incorrectly increase the source current and burn out the cathode.

3. For beam blanking:
 - a. With a LabVIEW program only, set the **Blanker** toggle switch to **ON**.
 - b. Using the **BLANKER** control (encoder wheel or computer control), adjust the variable Blanker supply to the voltage that stops the beam. Monitor this supply with the Blanking meter on the display panel or computer.
 - c. Determine the appropriate blanker voltages needed to blank the beam. (See graphs in the Data Section). Due to small system variations, the user should independently confirm that beam blanking is achieved, i.e. that there is no beam at the target.
 - i. If the blanker voltage is **too low**, the beam will not be deflected into the beam trap.
 - ii. If the voltage is **too high**, there may be some scattering, so do not simply set the blanker voltage to the maximum.
 - d. The voltage required to blank the beam increases linearly with Energy, and so **Blanker Voltage must be readjusted as the Energy is varied.** If desired, set the Blanker output to be proportional to Energy using the **MENU** button and **set proportional outputs.** Set **SLAVE OUTPUT: BLANKER** and **SOURCE OUTPUT : ENERGY.**
 - e. Depending on the operating conditions, the voltage applied to the blanker plate, and the amount of electron scattering inside the gun, there may still be some beam current at the target, when the blanker is on; further adjustment of parameters may be needed.
4. For normal beam operation: Using the **BLANKER** control (encoder wheel or computer control) set the Blanker voltage to zero. Alternatively, with a LabVIEW program only, set the **Blanker** toggle switch to **OFF**.

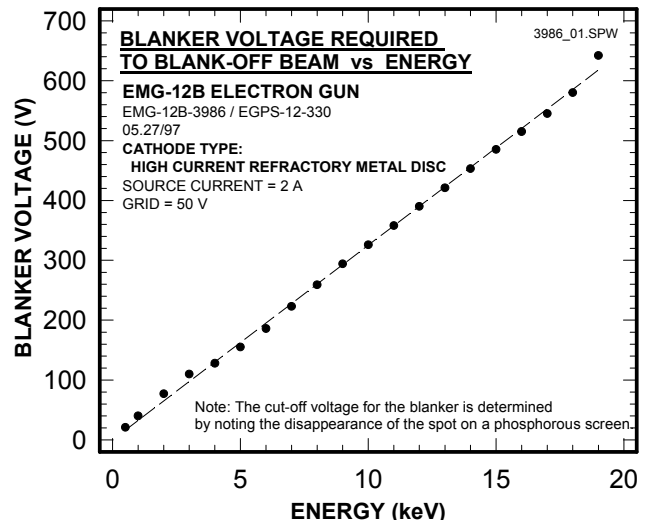
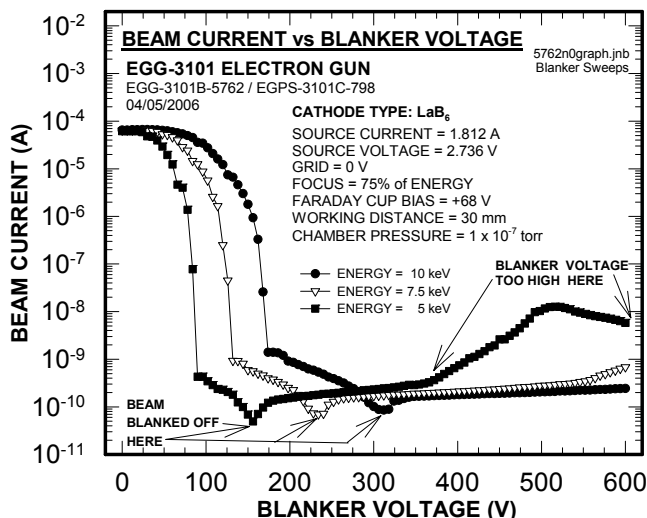

Fig. 4.9-2 Typical blanker voltages required to blank-off the electron beam, minimum points on Beam Current vs Blanker Voltage graph (Actual values will vary with gun model and options; see Data Section for more specific graphs)

4.9 BEAM BLANKING AND PULSING OPTIONS cont.

4.9.2 TTL-SWITCHED PULSING WITH BEAM BLANKER

With TTL-switched pulsing, the blanker power supply is switched off and on in the EGPS unit in response to a TTL signal input. A TTL (transistor-transistor logic) pulse source is required, such as a separate user-supplied pulse generator unit.

Typically, beam pulse widths from 1 μ sec to DC and repetition rates up to 5 kHz maximum can be achieved with appropriate TTL inputs. Higher repetition rates may be available.

A pulsing TTL (transistor-transistor-logic) signal rapidly switches the output voltage to the Blanker plates between ground, which does not interfere with the beam, and the variable Blanker voltage which is set to displace the beam. This pulses the beam on and off, as shown in Fig. 4.9-3. For example, if the blanker voltage is adjusted to -500 V, the blanker element in the gun will be at -500 V when the TTL signal is 0 V and the beam will be blanked off, the blanker will be grounded when the TTL signal is +5 V and the beam will be on.

Note that whenever there is a zero-volt TTL signal, the beam can be shut off by the blanker if the blanker voltage is set high. When there is no TTL input, the power supply will provide a +5 V signal, so that the output will be at ground and the beam can be on. Thus for start-up and normal non-pulsed gun operation, the Blanker voltage control must be set to zero (or the TTL generator must be either disconnected or provide a constant +5 V signal input).

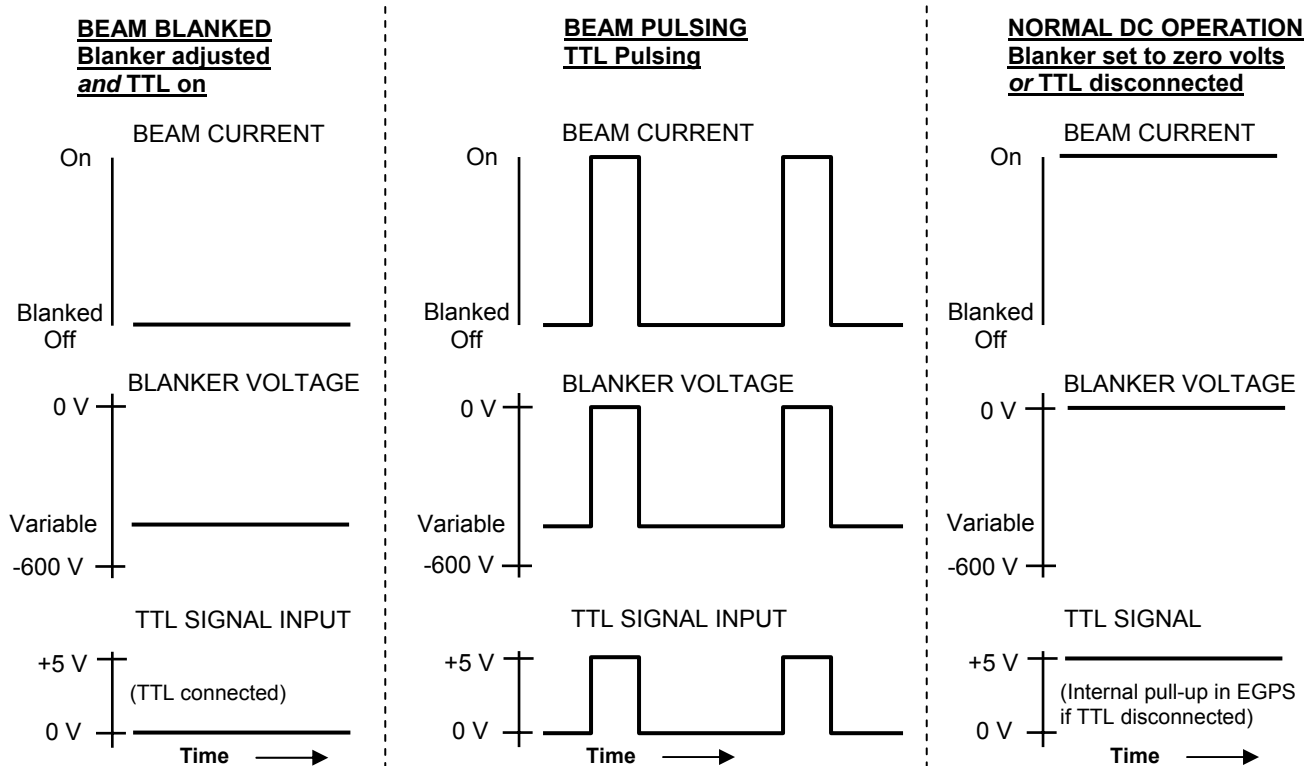

Fig. 4.9-3 Beam Blanking: TTL pulsing signal, blanker response to signal, and final beam current response. (Voltage values depend on the particular gun model and options.)

4.9 BEAM BLANKING AND PULSING OPTIONS cont.

CAUTION

The blanker BNC on the electron gun must always be connected to the blanker power supply via its coaxial cable or else shorted to ground.

For gun start up or DC operation, the Blanker voltage must be set to 0 V or TTL pulse generator must be disconnected or provide a constant +5 V signal.

OPERATION OF TTL-SWITCHED PULSING WITH BEAM BLANKER

1. Set up:
 - a. Connect the Blanker coaxial cable between the **BLANKER OUT** BNC on the EGPS Power Supply and the Blanker BNC on the electron gun. **CAUTION: The gun BNC must always be connected to the power supply or else shorted to ground, even if blanking is not being used.** This is necessary to prevent the blanker plates inside the electron gun from charging up during normal operation.
 - b. A separate, user-supplied 0 to +5 VDC TTL pulse generator is required for Beam Blanking. Alternatively, the TTL signal can be generated by the user's computer program.
 - i. Using a user-supplied coaxial cable, connect the TTL source to the BNC labeled **TTL IN** on the back of the EGPS.
 - ii. Monitor the input signal with an oscilloscope.
 - iii. With optional rastering, a BNC-T can be used to also connect this BNC to the Raster Generator Deflection Unit for synchronization.
 - c. (Optional) Monitor the beam current using a Faraday cup at the end of the gun, connected to a high speed current amplifier which is then connected to an oscilloscope. The amplifier is needed due to the input capacitance of the oscilloscope, and must have a rise time fast enough for pulse width desired.
2. **CAUTION:** A Pulse Junction Box must not be connected to the gun when using TTL-switched pulsing.
3. For start up:
 - a. Follow the Normal Start Up Procedure, Section 4.2. or 4.3 to begin gun operation. ECC (emission current control) is allowed with pulsing using the beam blanker.

CAUTION: For initial start-up and non-pulsing DC gun operation, the blanker voltage must be 0 V or the TTL source must be disconnected or provide a constant +5 V signal input. With a LabVIEW program the Blanker switch should be set to off. If the Blanker is high and the TTL signal input is 0 V, the beam will be cut-off even if the cathode is on. This could cause the user to incorrectly increase the source current and burn out the cathode.
4. Turn on beam blanking:
 - a. Turn on the user-supplied TTL source.
 - b. Set the TTL input to **0 V** to enable the Blanker power supply.
 - c. With a LabVIEW program only, set the **Blanker** toggle switch to **ON**.
5. Set the Blanker voltage:
 - a. Using the **BLANKER** control (encoder wheel or computer control), adjust the variable Blanker supply to the voltage that stops the beam. Monitor this supply with the Blanking meter on the display panel or computer.
 - b. Determine the appropriate blanker voltages needed to blank the beam. (See graphs in the Data Section). Due to small system variations, the user should independently confirm that beam blanking is achieved, i.e. that there is no beam at the target.
 - i. If the blanker voltage is **too low**, the beam will not be deflected into the beam trap.
 - ii. If the voltage is **too high**, there may be some scattering, so do not simply set the blanker voltage to the maximum.
 - c. The voltage required to blank the beam increases linearly with Energy, and so **Blanker Voltage must be readjusted as the Energy is varied.** If desired, set the Blanker output to be proportional to Energy using the **MENU** button and **set proportional outputs**. Set **SLAVE OUTPUT: BLANKER** and **SOURCE OUTPUT : ENERGY**.
 - d. Depending on the operating conditions, the voltage applied to the blanker plate, and the amount of electron scattering inside the gun, there may still be some beam current at the target, when the blanker is on; further adjustment of parameters may be needed.
6. Set the pulse rate:
 - a. On the TTL generator, adjust the TTL input signal pulse rate, frequency and duty cycle as desired.
7. For constant beam operation (DC), no blanking:
 - a. With FlexPanel controls only, set the **BLANKER** control to 0 V with the encoder wheel, or provide a constant +5 V TTL signal input, or disconnect the TTL source.
 - b. With a LabVIEW program only, set the **Blanker** toggle switch to **OFF**. The blanker voltage and pulse generator may remain as set.

TTL input	Blanker Voltage	Result
+5 V	Grounded	Beam ON
0 V	Variable	Beam OFF (BLANKED)

4.9 BEAM BLANKING AND PULSING OPTIONS cont.

4.9.3 CAPACITIVE PULSING WITH BEAM BLANKER AND PULSE JUNCTION BOX

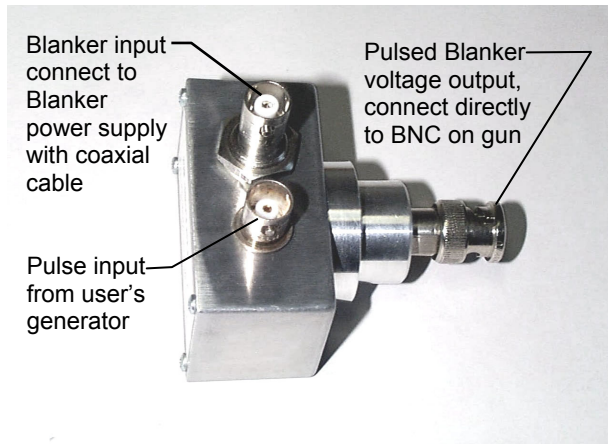

Fig. 4.9-4 A capacitive Pulse Junction Box, showing connections for a beam blanker

This capacitive pulsing option involves a capacitor-containing device, the Pulse Junction Box, that is attached to the Blanker BNC on the electron gun. A separate, user-supplied pulse generator capable of producing appropriate voltages (equal to the Blanker voltage) is also required. In the Pulse Junction Box, the voltage outputs from the Blanker power supply and pulse generator are combined to produce the voltage at the blanker plate in the gun to pulse the beam off and on.

Capacitive pulsing can provide the fastest rise/ fall time and shortest pulse length of the various pulsing methods. However, the capacitor does not permit long pulses or DC operation.

PULSE JUNCTION BOX: INSTALLATION

1. See Fig. 4.9-6 below for a diagram of equipment layout. Also refer to the power supply and electron gun installation procedures in Sections 2.2 and 2.3.
2. **CAUTION:** The **TTL IN** BNC on the back of the EGPS must be covered with a shorting BNC connector or a 50 Ω terminator to enable blanking.
3. Connect the Pulse Junction Box as shown in Fig. 4.9-4 and Fig. 4.8-2.
 - a. Connect the output of the Pulse Junction Box directly to the Blanker BNC on the electron gun.
 - b. Connect the larger BNC of the Blanker cable to the Blanker input BNC on the Pulse Junction Box. Connect the smaller BNC on the other end to the BNC labeled **BLANKER OUT** on the EGPS Power Supply.
 - c. Using a user-supplied coaxial cable, connect the pulse input BNC (the shorter BNC) on the Pulse Junction Box to the output of the user-supplied pulse generator.
4. Optional: Set up a user-supplied oscilloscope or other equipment to monitor pulsing; a terminating resistor may be needed. (Fig. 4.9-6)

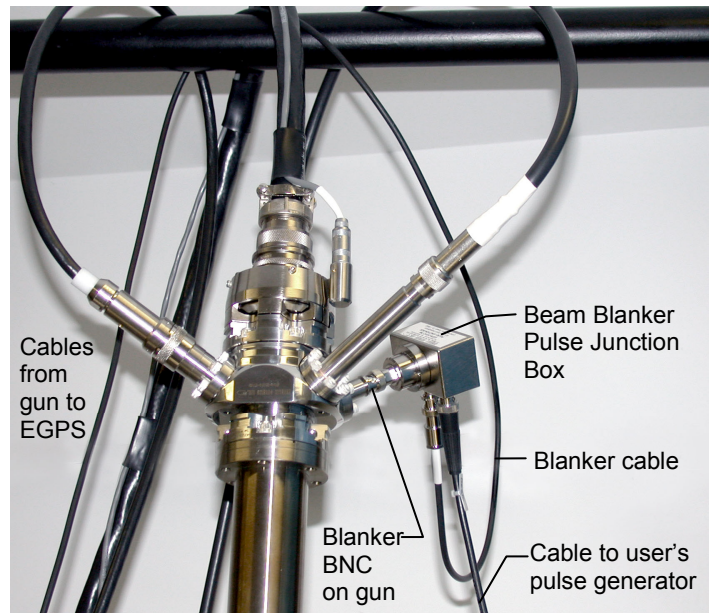

Fig. 4.9-5 A typical Electron Gun installed in vacuum with a Pulse Junction Box attached to the Blanker BNC

POWER INPUT CAUTIONS

The maximum average power recommended for the standard Pulse Junction Box is 1 WATT. The circuitry in the box includes a 50 Ω resistor for termination to ground. The power input from the user's pulse generator must be kept low enough so that the resistor will not be damaged.

The power input can be calculated using the following equation:

$$V^2 / R = P \text{ (the total DC power).}$$

For example, if 100 V from the user's pulse generator is applied to pulse the beam, 100 V squared divided by the 50 Ω resistor equals 200 Watts continuous DC power, which would quickly destroy the circuitry in the box.

With pulsing, the overall power input is reduced, as calculated by the following equations:

Pulse width (duration of pulse) x frequency = duty cycle (fraction of time the beam is on) and

$$\text{Duty cycle} \times \text{total } P = \text{Avg pulsed Power.}$$

For example, with a 5 μsec pulse at 1 kHz, the time on is 5×10^{-6} sec multiplied by 10^3 cycles/sec which equals 0.005 or a 0.5% duty cycle. Thus the average pulsed power with a 100 V input would be 0.005 times the 200 W which equals 1 Watt, the limit of what is considered safe for the Pulse Junction Box. Either a higher voltage input or longer pulses or a higher frequency could damage the circuitry.

Thus, before operating, it is important to calculate the expected pulsed power input. There can also be a problem with very long pulses; the Pulse Junction Box is designed for fast pulsing. Pulse widths from 20 ns to 100 μs can be achieved with appropriated inputs. Some examples of allowable pulsing parameters are given in Table 4.9-1 on the next page.

4.9 BEAM BLANKING AND PULSING OPTIONS cont.

CAPACITIVE PULSING with BEAM BLANKER and PULSE JUNCTION BOX cont.

CAUTION

DO NOT EXCEED 1 WATTS AVERAGE INPUT
due to 50 Ω input impedance.

The input BNC on the Pulse Junction Box must NOT be grounded, even when not in use.

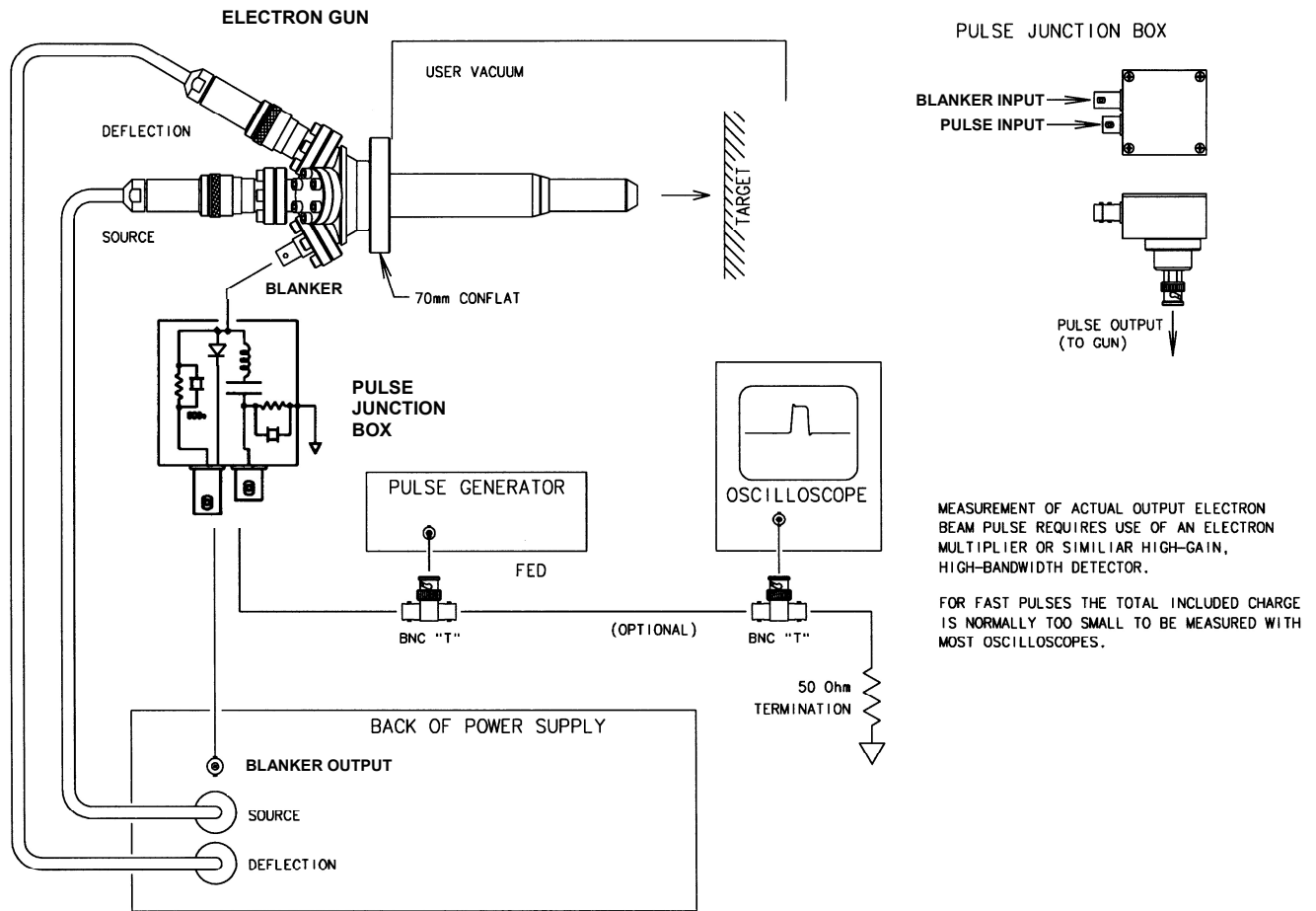

Fig. 4.9-6 Pulse Junction Box connections to gun, power supply and user-supplied equipment

Table 4.9-1 Pulse Input Limits for Standard Pulse Junction Box

Pulse Voltage Input (depends on gun model)	Pulse Width	Pulse Frequency (Repetition Rate)	Average Power (calculated)
25 V	20 ns	4 MHz	1 W
	100 μs	800 Hz	
100 V	20 ns	250 kHz	
	100 μs	50 Hz	
500 V	20 ns	10 kHz	
	100 μs	2 Hz	

4.9 BEAM BLANKING AND PULSING OPTIONS cont.

PULSE JUNCTION BOX: DESCRIPTION of PULSING VOLTAGES and BEAM RESPONSE

Pulsing of the beam current is accomplished by sending a pulse through a capacitor to the blanker deflection plate in the gun. The general pattern of the beam pulsing is a square wave with a variable width (time off and time on) and a variable repetition rate. A pulse width from 20 nsec to 100 μ sec can be created with an appropriate pulse generator.

The blanker voltage is negative, so to cancel the blanking and pulse the gun on, positive voltage pulses are required. The blanker voltage on the EGPS Power Supply should be turned up so that the electron beam is completely blanked off. Data is supplied in the Data Section showing the blanker cutoff values for the gun. By sending a pulse of the appropriate amplitude through the Pulse Junction Box, the gun will be turned on for the duration of the pulse.

A capacitor in the Pulse Junction Box isolates the blanker voltage from the pulse generator. The pulse is transmitted from a ground-referenced pulse generator, through this capacitor to the blanker plate.

A diode in the box clamps the voltage output to the blanker plate so that it can not become positive and the beam will not move off center towards the plate. Thus it is possible to slightly overdrive the pulsed input (make it slightly greater than the blanker voltage) which can reduce ringing from the pulse generator.

The figure below illustrates the beam current response in fast beam pulsing. The blanker power supply and pulse generator outputs superimpose to produce the voltage applied to the blanker plate. The electric field in the blanker region then controls the electron beam; a negative voltage deflects the beam into the blanker trap, while zero allows the beam to pass through to the target.

For example with a blanker power supply that can be varied from 0 to -600 V, a blanker cut off voltage of -400 V plus a positive pulse of +400 V (or slightly higher) yields a pulse of 0 V (ground) on the blanker inside the gun. This combined voltage then pulses the beam on. The values shown for illustration purposes are for a typical high current EGG-3101 Electron Gun. The actual values of blanker voltage and beam current will vary with the gun model and operating parameters, such as Energy. (See Data Section).

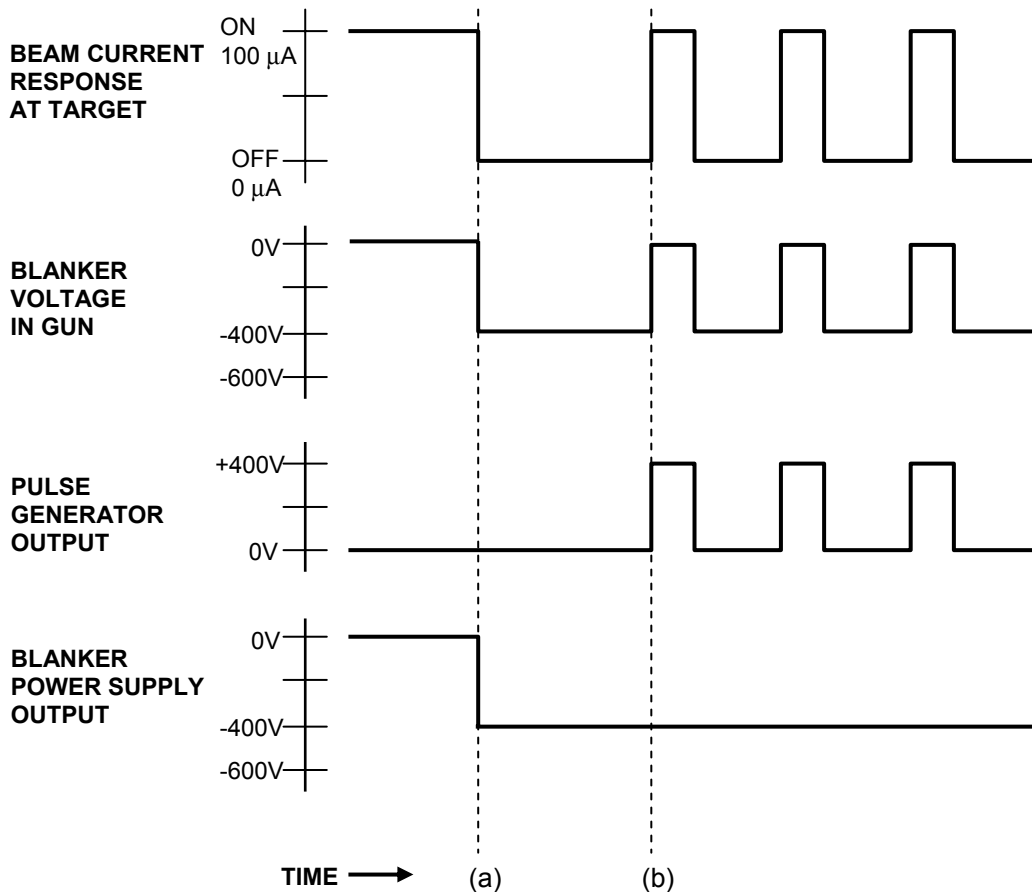



Fig. 4.9-7 Capacitive Fast Beam Pulsing diagram: At time (a) the blanker power supply control is set to the cut off voltage, and at time (b) the pulse generator is turned on. (Voltage values depend on the particular gun model and options.)

4.9 BEAM BLANKING AND PULSING OPTIONS cont.

OPERATION OF CAPACITIVE PULSING WITH BEAM BLANKER AND PULSE JUNCTION BOX

	 CAUTION
	DO NOT EXCEED 1 WATTS AVERAGE INPUT due to 50 Ω input impedance. The input BNC on the Pulse Junction Box must NOT be grounded, even when not in use.



1. Calculate the expected power in the Pulse Junction Box, based on the desired pulse length and frequency and the blanker cutoff value for the particular gun. See Power Input Cautions and Table 4.9-1 above.
2. For Start up:
 - a. Follow the Normal Start Up Procedure, Section 4.2. or 4.3 to begin gun operation. ECC (emission current control) is allowed with pulsing using the beam blanker.

CAUTION: For initial start-up and non-pulsing DC gun operation, the blanker voltage must be 0 V. If the Blanker is on, the beam will be cut-off even if the cathode is on. This could cause the user to incorrectly increase the source current and burn out the cathode.

3. Set the Blanker voltage:
 - a. Using the **BLANKER** control (encoder wheel or computer control), adjust the variable Blanker supply to the voltage that stops the beam. Monitor this supply with the Blanking meter on the display panel or computer.
 - b. Determine the appropriate blanker voltages needed to blank the beam. (See graphs in the Data Section). Due to small system variations, the user should independently confirm that beam blanking is achieved, i.e. that there is no beam at the target.
 - i. If the blanker voltage is **too low**, the beam will not be deflected into the beam trap.
 - ii. If the voltage is **too high**, there may be some scattering, so do not simply set the blanker voltage to the maximum.
 - c. The voltage required to blank the beam increases linearly with Energy, and so **Blanker Voltage must be readjusted as the Energy is varied.** If desired, set the Blanker output to be proportional to Energy using the **MENU** button and **set proportional outputs.** Set **SLAVE OUTPUT: BLANKER** and **SOURCE OUTPUT: ENERGY.**
 - d. Depending on the operating conditions, the voltage applied to the blanker plate, and the amount of electron scattering inside the gun, there may still be some beam current at the target, when the blanker is on; further adjustment of parameters may be needed.

4. On the user-supplied pulse generator, set the input pulse:
 - a. Turn on the generator, and set the desired pulse rate.
 - b. Adjust the positive input voltage to the Pulse Junction Box to the same value as the Blanker voltage set on the EGPS or computer panel. The input voltage can be slightly higher to reduce ringing. **CAUTION: Do not exceed 1 W average power input.**
 - c. Using an oscilloscope, the pulse amplitude and the voltages can be fine-tuned to reduce ringing and improve beam output. Note: When monitoring the beam pulse, the input impedance of the oscilloscope may need to be changed by use of a terminating resistor.
5. When not using the pulsing option: Disconnect or turn off the user-supplied pulse generator. The pulse input BNC on the Pulse Junction Box must NOT be grounded even when not in use. If the input BNC is grounded, the blanker in the gun will be grounded, and not at the voltage set.

NOTE: The Blanker Coaxial Cable must always be connected between the gun and the EGPS Power Supply (with or without the Pulse Junction Box between).

	 WARNING
	HIGH VOLTAGE can cause ELECTRIC SHOCK Internal capacitors in the pulse junction box could remain charged. Use caution to avoid shocks. Do not touch terminals on the box immediately after use.

This completes the Beam Blanking Instructions.