

FLEXIBLE COMPACT UHV CF FITTINGS

EXCEPTIONAL ACCESS, INTERNAL APPARATUS MOUNTING SYSTEM

PATENTED

APPLICATIONS:

- COMPACT UHV CHAMBERS
- PRECISION INSTRUMENT HOUSINGS
- PORTABLE LOW-COST UHV SYSTEMS
- HIGH-COMPLEXITY UHV SUBSYSTEMS
- UHV MANIPULATORS
- ELECTRON GUN / ION SOURCE HOUSINGS
- DETECTOR HOUSINGS / SUBSYSTEMS
- FEEDTHROUGH CLUSTERS
- MINIATURE UHV PUMPING SYSTEMS

Multi-CF SERIES FEATURES:

- EXCEPTIONAL INTERNAL ACCESS
- REDUCED VACUUM SYSTEM SIZE AND MASS
- PRECISION GROOVE-GRABBER / GRABBER-GROOVE INTERNAL APPARATUS ATTACHMENT SYSTEM
- MAXIMUM INTERNAL VOLUME FOR A GIVEN CF SIZE
- COMPLEX CUSTOM CAPABILITIES AT OFF-THE-SHELF PRICES
- INCREASED PUMPING SPEEDS
- GROOVE GRABBERS COMPATIBLE WITH eV Parts®
- COMPATIBLE WITH MINIATURE PUMPS, GAUGES, AND OTHER UHV VACUUM APPARATUS
- COMPATIBLE WITH STANDARD CF FLANGES
- HIGH RIGIDITY / HIGH ACCURACY / HIGH OVERALL QUALITY
- NEAR-MIRROR, UHV CLEAN INTERIOR SURFACE FINISHES
- UHV BAKEABLE TO 450°C
- CONTINUOUSLY EXPANDING LINE OF PARTS AND FITTINGS



Flange Multiplexer MCF275-FM4R04-A



Spherical Square MCF600-SS200408-A

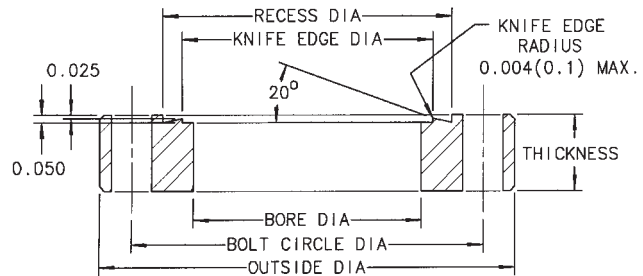

NOMINAL SIZE	CONFLAT OUTSIDE DIA.	Multi-CF OUTSIDE DIA.	CONFLAT BORE DIA.	Multi-CF BORE DIA.	CONFLAT GASKET I. D.	Multi-CF GASKET I. D.	CONFLAT THICKNESS	RECESS DIA.	KNIFE EDGE DIA.	BOLT CIRCLE DIA.	CONFLAT NUMBER OF HOLES*	Multi-CF NUMBER OF HOLES*	BOLT HOLE DIA.	THREADED HOLE	n
1½ CF	1.33	same	0.625	0.640	0.640	0.640	0.285	0.840	0.720	1.062	6	6/12	0.172	8-32	0
2¾ CF	2.73	same	1.375	1.500	1.450	1.510	0.500	1.900	1.650	2.312	6	6/12	0.265	1/4-28	2
4½ CF	4.47	4.13	2.375	2.900	2.500	2.910	0.680	3.250	3.040	3.628	8	8/16	0.332	5/16-24	4
6 CF	5.97	same	3.812	4.300	4.000	4.310	0.840	4.750	4.540	5.128	16	16/32	0.332	5/16-24	6
8 CF	7.97	same	5.812	6.300	6.000	6.310	0.940	6.750	6.540	7.128	20	20/40	0.332	5/16-24	---

Multi-CF NUMBERING SYSTEM AND ABBREVIATIONS:

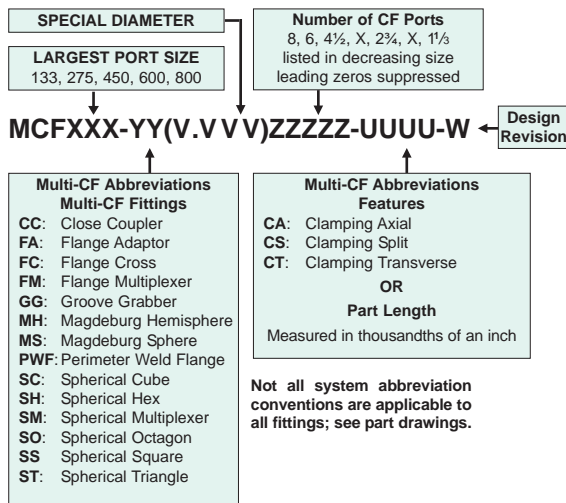

* Number of bolt holes given as: single density/double density. Double density allows for more flexibility in angular positioning; only 1/2 of the double density holes are normally used.

BOLT TYPE, LUBRICATION, AND LENGTH

The use of 12-point-head silver-plated bolts, of proper length, is assumed. The 12-point heads fit smaller size wrenches, as required for wrench clearance on many fittings.

Lubrication is essential. Silver-plating on bolts is the preferred clean, bakeable method of insuring adequate lubrication.

Bolt lubrication is a critical issue with all CF flanges, but is especially important with Multi-CF Fittings because of the large number of tapped holes. In the worst case, a jammed bolt can ruin a part. Other methods of lubrication, such as the use of molydisulfide are also satisfactory. Holes must be kept clear of grit, etc., that may initiate galling. Worn or damaged bolts should not be used (and should be discarded). Using silver-plated studs and unplated nuts, where applicable, can further reduce risk.

Proper bolt length is important. Thread engagement that is too short, overstresses the mating threads. Bolts that are too long may bottom out or, with some types of Multi-CF Fittings, may even collide with a bolt in an intersecting hole. Bolt length is best checked prior to assembly.

GASKET CRUSHING ALLOWANCES

In general with copper gasket use, mating CF flanges are not crushed together to zero gap. A typical remaining gap is roughly 0.020 inches. Multi-CF Fittings have been designed to provide assembled center-to-center spacings which are multiples of 0.700 inch. In order to maintain this 0.700 inch spatial periodicity, each CF face has been set back in by a gasket crushing allowance of 0.010 inch (0.25 mm).

For example, a MCF275-CC700-A Close Coupler that has a nominal distance of 0.700 inch between opposite gasket center planes, has an actual thickness of 0.680 inch (=0.700 - (2 x 0.010)).

Multi-CF™ PATENTS

The Multi-CF line is covered by patents:
 5,593,123; 5,625,947; 5,660,418; 5,671,956;
 6,270,045 Additional patents pending

THE NEED

Ultra-High-Vacuum ConFlat flanges¹ with their associated fittings have now been the industry standard method for achieving the best attainable vacuums for several decades. In the early 1960's, ConFlat systems replaced both hand-blown glass vacuum systems, which could reach good vacuums, but had almost impossible access, and O-ring systems, which had easy access, but could not reach UHV. During the succeeding decades, surface physics, atomic physics, mass spectrometry, accelerator physics, molecular beam epitaxy and semiconductor manufacturing, high-resolution microscopes, plasma physics, fusion research, and various other areas of science and technology have all come into their own. All of these technologies are based on the clean reliable vacuums, with reasonably easy access, which ConFlat fittings provide. Without the invention of this enabling core technology (or some equivalent), much of modern science would not have been possible.

The ConFlat flange industry has now been stable for many years, with numerous companies making commodity products. However, the industry currently faces both new challenges and significant new opportunities. There have been paradigm shifts, both in what is needed, and in what is possible.

New scientific experiments, new types of analytical instruments, and new industrial processes, which require various degrees of ultra high vacuum, are continuously being developed. There is a major need for vacuum housing designs which embody structural rigidity, compactness, flexibility, accuracy, cleanliness, portability, low cost, and the like.

On the other hand, much more is now possible. New materials, better methods of design, and more sophisticated fabrication techniques, are only beginning to be utilized. Better computers are facilitating faster and more powerful computer aided design, along with more accurate stress-strain analysis for optimizing structures. New fabrication techniques include more flexible computer-numerical-control machines, faster and more versatile electrical discharge machines, computer-controlled processing, and better joining methods. Of particular importance is the manner in which improved machining techniques have changed the relationship between complexity and cost; i.e., significantly more complex shapes can now be manufactured without commensurate increases in cost.

Historically, ConFlat flanges were conceived mostly as vacuum plumbing fittings, rather than as support structures for complex UHV instruments or scientific devices. Plumbing fittings were what was needed at the time. By contrast, Multi-CF™ fittings are being designed as instrument housings and as vacuum chambers, with the specific design intent that they conveniently support all kinds of internal apparatus, permit complex port arrangements, maximize interior volume, provide easy access, improve pumping, follow a modular dimensioning system, permit OD-ID adjacent-size nesting, and cluster together in close proximity. In addition, they need to maintain compatibility with the existing fittings currently available from many manufacturers.

The advantages of compactness are often under recognized. Compactness often permits improved instrument performance, lighter systems, better rigidity, smaller pumping systems, easier portability, and almost always lower total cost.

A vacuum system should have a synergistic relationship with the equipment it contains. Ideally, an instrument housing for example, should be designed concurrently with the instrument itself, using the minimum required number of component parts. An entire design can then be simultaneously optimized. If it is not practical to design concurrently, then at least more advanced standard fittings should be available, fittings which have been designed with the specific goal of making chambers, instrument housings, or whatever.

DESIGN CONSIDERATIONS

FABRICATION METHODS AND SHAPES

Heliarc welding has been the normal method of fabricating vacuum plumbing and chamber components for years. Flanges, each with a single sealing surface, are welded to tubing segments of varying diameters and lengths, which are also welded to each other.

The components are then bolted together using sealing gaskets. But the resulting vacuum structures are often large and gangling. Often the exterior space taken up is many times larger than the useful interior space (as if laboratory space were free, which it isn't). Even the interior space is frequently designed much larger than it really needs to be. The root difficulty here was the initial decision to construct the system using only simple flange fittings. Fortunately, this is only one of several possible methods for building structures.

The basic idea of Multi-CF fittings is to reduce the number of components by machining multiple sealing surfaces onto single pieces of metal.

Heretofore, nearly all ConFlat flanges have been lathe machined in their conventional shape, i.e. flat right-circular cylinders (though some have been symmetrically machined onto the faces of cubes). Other shapes are possible. A particularly attractive design is to machine conflat-type seals into thick-walled hollow spherical shells. A plane intersecting with a sphere always generates a circle. Controlling the distance of the plane from the center of the sphere fixes the circle's diameter. By using various planes at varying distances and orientations from the sphere origin, numerous ports of varying sizes can be machined into a sphere or partial sphere. A part which previously had to be welded up out of many pieces can now be manufactured as a monolithic structure, with all, or at least most, of the part machined out of a single metal billet. The thick shell wall (with a thickness roughly equal to a flange thickness), accepts tapped bolt holes for gasket compression. Controlling bolt-circle angular orientations frequently allows the bolt holes of adjacent ports to be interleaved, thus making quite compact structures. The spherical inside of the hollow spherical shell tends to increase useable space, as well as to maximize the interior-volume to interior-surface ratio. The (mathematically) compound curvature of all spherical shapes results in inherently strong structures. A major fraction of Multi-CF designs include at least a fractional segment of a sphere. An important supporting technology here, which makes the designs practical, is the ability to machine the axially symmetric sealing surface shapes using CNC mills instead of CNC lathes.

Because of the hole-interleaving effect, the smaller unitary fittings are often lighter than their welded counterparts. In addition, they are cleaner, stiffer, more rigid, and better aligned. A major disadvantage of unitary constructions, however, is that they tend to become unnecessarily heavy as their size increases. Also, the hole interleaving effect becomes less useful as size increases.

1)The ConFlat flange was invented by Bill Wheeler at Varian Associates; ConFlat is a registered trademark of Varian Associates.

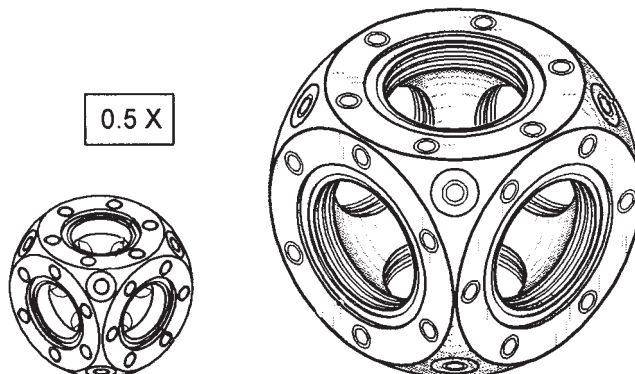

COST CONSIDERATIONS

There is an interesting question as to when it is less costly to use monolithic machined parts, versus conventional welded constructions. It turns out that the optimum method for constructing a particular vacuum structure has a lot to do with geometric size scaling laws.

In constructing a vacuum system, what one is really making is a vacuum barrier, a wall which separates an experiment, instrument, or process from the rest of the local environment. The benefit is the enclosed volume, which scales as length cubed. However the barrier, the vacuum wall, has an area which scales as length squared. For welded fabrications, the material cost, to first order, is proportional to wall area. This is a result of the raw materials starting out as mostly sheet and thin-walled tubing. Additionally the welding cost itself also tends to be roughly proportional to wall area. However, for monolithic machined parts, both the cost of the raw material, and the cost of removing unwanted material goes as the volume, scaling as length cubed. This means that for smaller sizes, monolithic structures have a lower cost, while for larger sizes, welded structures are more cost effective. (Visualize the cost of a large MBE chamber machined out of a single billet.) The situation here is somewhat complicated by various related costs which do not follow a simple model; these include the costs associated with each port opening, and costs related to special specific geometries. Nonetheless, as a rough rule of thumb, the practical cost crossover point lies in the range of a 200 mm major dimension. In many cases a combination of methods is the best choice. Most often, the capability to adequately address the task at hand is a more important factor than cost.

Note that Multi-CF designs become less competitive when the number of ports is small. In such cases, a lot of thick wall is being wasted. The designs which have the best market acceptance seem to be those where all possible ports are included.

To a degree, monolithic structures substitute machine-tool time (which is dropping in cost), for the hand labor involved in jiggling, multiple welds, and weld cleanup (which is rising in cost).

Most chambers presently produced in the vacuum industry are custom fabricated. Custom fabrication is expensive. By providing multiple-port Multi-CF chambers as off-the-shelf standards, the percentage of custom work required is reduced. With Multi-CF fittings, a chamber may be a single part. The result is reduced costs. Additionally, customization of Multi-CF fittings is also possible; frequently it is easy.

Perhaps the most important advantage of monolithic structures is that they allow the attainment of geometries simply not achievable by other techniques.

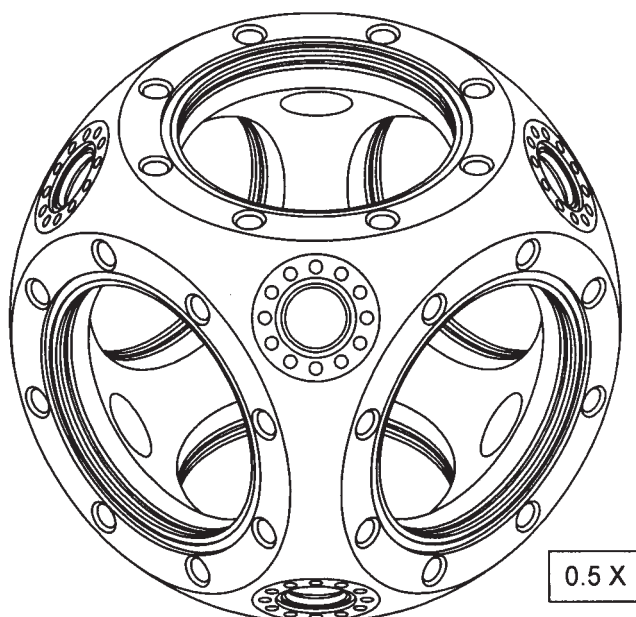

IMPROVEMENTS TO EXISTING DESIGNS

In addition to the use of new and different complex shapes, small changes in the existing standard flange designs can improve performance, while still maintaining compatibility with existing flanges.

FLANGE CROSS SECTIONAL SHAPES

The strength of a vertically loaded beam is proportional to $B \times H^3$, where B is the width of the beam, and H is its height. A CF flange is simply a beam wrapped into a circle, with bolt generated point loads on one side, opposed by a uniform gasket crushing force on the other. Since the cross sectional area of a beam (or flange) is $B \times H$, the most efficient use of material is to have a small B and a large H. This implies the use of thick flanges of small radial extent. For compatibility, sealing surface dimensions, gasket outside diameter, gasket thickness, bolt circle diameter, bolt threads, bolt engagement lengths, and thermal expansion coefficients, must not be changed. However, inside flange diameter, gasket diameter, outside flange diameter, and flange thickness all may be varied. Additional bolt holes may be added. Variations of this sort have been made by a number of people over a period of years. What is new in the Multi-CF line, as related to these issues, is the attempt to promulgate a number of changes simultaneously, and the imposition of a modular dimensioning system (with many dimensions determinable from simple formulas). Also, the diameters have been set to allow the outside diameter of one size to fit through the inside diameter of the next larger size, up to the 8 inch size.

INCREASES IN BORE SIZES

An important improvement which has already been implemented by numerous users is the use of larger bores. A larger bore size permits larger apparatus to be inserted, gives improved access, and provides a slightly improved pumping speed. It is important not to increase the diameter by so much that the knife edge diameter is approached. It is largely the spacing between the knife edge and the bore edge which protects the knife edge from damage.

INCREASES IN GASKET INSIDE DIAMETERS

In order to take full advantage of larger bore sizes, it is necessary to increase the gasket inside diameters. The obvious inside diameters are those diameters which are just slightly larger than the largest normally-used inside diameter of the corresponding flange. Gaskets with larger inside diameters for the 2 3/4 size have been commercially available for some time.

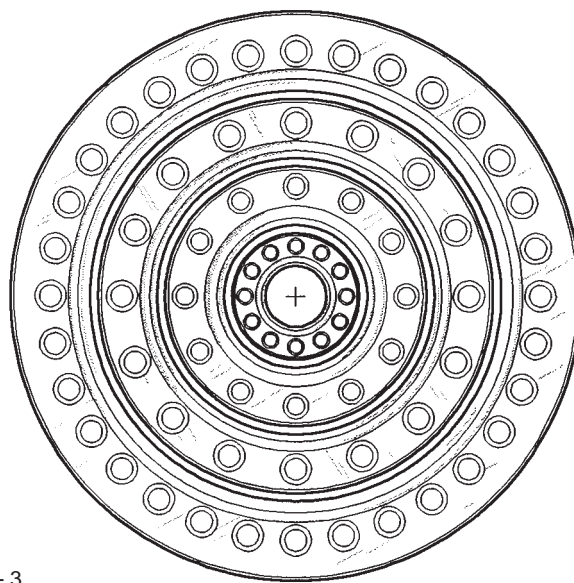

REDESIGN OF THE 4½ CF FLANGE

The CF flange size which has proved most amenable to improvement is the 4½ inch size. This size was the least optimized of the original series; however it is an important size with wide usage. Its ID was 2¾ inch as originally designed, to be compatible with welding to a 2.5 inch OD tube. This ID has now been increased to 2.900 inch allowing use of 3 inch OD tubes. The gasket ID has been similarly increased from 2.500 to 2.910 inch. Simultaneously, the OD of the 4½ CF size, originally manufactured as 4.470 inch, has been reduced to 4.130 inch. This allows it to nest with the new 4.300 ID of the 6 inch CF size, as well as getting rid of material which adds little strength.

The improvement in bore area here, which relates to pumping speed, is almost 50%. This bore area increase also means that larger instruments and devices will fit. An additional factor of practical significance, is that most human hands can fit through the new 2.900 bore, while many adult hands can not fit through the old 2¾ bore.

The rarely used 4¾ inch CF size, designed specifically for use with 3 inch OD tubes, no longer serves any useful need, and hence no longer needs to be supported.

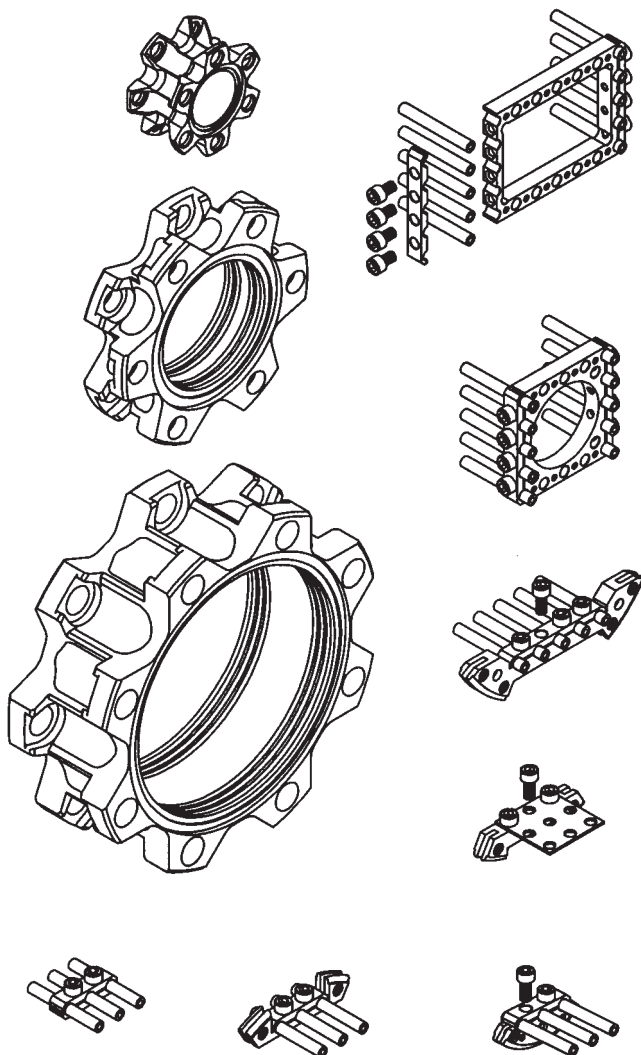

GASKET COMPRESSION BOLTS

The bolts used for gasket compression are a critical design issue. The most important point is the standardization on the already-widely-used 12-point bolt heads. It is the 12-point heads which make possible a number of new designs: new flanges, the redesign of the 4½ CF flange, close couplers and related parts, the Magdeburg hemispheres, etc.

The use of bolts with 12-point heads yields several advantages. Torque is transmitted from a wrench to a bolt through contact areas at the polygon points, six areas on a normal hex head bolt. The available torque is equal to the number of points, times the effective lever arm, times the force transmitted through the contact area at each point; while the point force is basically limited by the yield strength of the bolt material. Doubling the number of bolt points to 12, allows the lever arm to be cut in half while still achieving the same torque. This roughly halves the overall outside diameter of the bolt head. This size reduction in turn allows the use of smaller 12-point box wrenches, as well as smaller 12-point socket wrenches. It is these wrench size reductions which have facilitated some of the most important improvements of the Multi-CF series. Suitable bolts with 12-point heads do not appear to have been available at the time of the original ConFlat invention.

The head heights of 12-point heads and hex heads are roughly equal; however the head diameters differ by about a factor of two. Hence a box wrench has roughly a factor of two better resistance to rotation about the wrench handle axis. This improvement reduces wrench-slip-off events, which are common with hex heads, to almost zero for 12-pointers. Finally, 12-point heads allow somewhat faster tightening, saving time.

Bolt lubrication is another important issue. Multi-CF fittings typically contain many tapped holes; some fittings have over 100. Hence bolt galling and jamming must be engineered down to the point of being very rare. A bolt jamming rate of even one in a thousand is quite unacceptable. In the past, the mere possibility of jamming has led some designers to totally avoid tapped fittings. Fortunately the advent of silver-plated bolts (not the nuts) in recent years seems to have eliminated this problem. It is necessary to religiously use proper bolts, with silver plating or equivalent lubrication, and to replace bolts when the plating starts to wear off. However, with proper care, it seems the jamming problem is gone; it is clearly well below the just-mentioned one in a thousand rate.

An increased variety in bolt lengths is becoming available. Shorter bolt lengths are particularly useful; and it is generally preferable to use shorter bolts. Shorter bolts have less bolt twist-up, less stretch, and less thermal creep. Moreover, as described below, shorter bolts allow fittings to be clustered closer together, a major issue in optimizing designs.

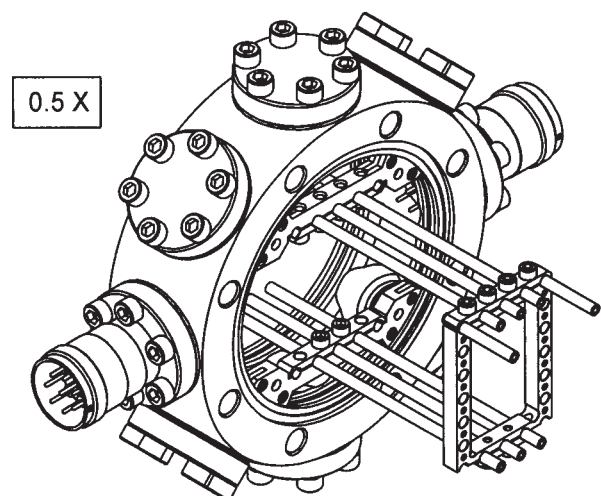

NEW DESIGNS

A number of unique features and new fittings provide an additional basis for the Multi-CF fitting product line.

INTERNAL APPARATUS MOUNTING

A particularly useful feature is the implementation of a flexible method of mounting apparatus on the inside of vacuum systems. Called the Groove-Grabber / Grabber-Groove system for internal-apparatus attachment, this technology permits easy mounting of almost any kind of equipment or device, off the inside diameter of any prepared flange or port. The Grabber-Grooves have the same cross-sectional design independent of the flange size. A number of different Groove-Grabber designs are available. Most are compatible with Kimball Physics eV Parts. Nearly all Multi-CF fittings are equipped with Grabber-Grooves.

CLOSE COUPLERS

Close couplers permit two fittings, each equipped with tapped holes, to be joined together with a minimum distance between them. They are based on an azimuthal staggering of oppositely-directed bolts, and the observation that full flange thickness is not needed directly underneath a bolt head. Reduced flange thickness under the bolt heads makes it possible to use shorter bolts. Because the space needed for bolt insertion is proportional to bolt length, and because there are two sets of oppositely-directed bolts, the minimum distance between the fittings decreases by much more than just the reduction in bolt length. Thus overall, one can obtain a major improvement in the minimum distance. A problem in the use of close couplers is that a rotation of one half of the bolt angular spacing is forced. However, if either of the fittings being joined has either a rotatable flange, or a double tapped bolt pattern, this difficulty is eliminated. It is also possible to eliminate the difficulty by use of a rotatable close coupler. Rotatable close couplers are just now being introduced (and will be included in the next catalog).

FLANGE ADAPTORS

Flange Adaptors permit the Groove-Grabber / Grabber-Groove attachment system to be used with arbitrary $2\frac{3}{4}$ CF and $1\frac{1}{2}$ CF feedthroughs made by any manufacturer. The feedthrough, most often an electrical feedthrough or a manipulator, is bolted to the adaptor. Apparatus is then attached using Grabber-Grooves which are machined in the inside bore of the adaptor.

PERIMETER WELD FLANGES

A new class of weldable flange has been designed. Normal flanges are designed to weld to tubes of a diameter commensurate with the inside diameter of the flange, with the weld occurring on the inside diameter about half a flange thickness away from the sealing surface. The new flanges, called Perimeter Weld Flanges, are welded around the outside perimeter of the flange on the back side of the flange. They are particularly suited to welding into thin wall spherical shells. However they may also be welded to larger diameter tubes, plates, cones, ellipsoids, and other shapes. By moving the weld location, it is possible to directly weld the flange into a spherical chamber, without the need for the short cylindrical tube segment normally used. The required number of welds is reduced by half (from two to one per port). The weld is made through the inside diameter of the flange, thus maintaining the cleanliness condition of all inside welds. Because the flange hugs the chamber wall, because the inside diameter has been increased, and because the inside diameter is partly conical, access to the inside of the chamber has been substantially improved. Also, overall apparatus size is reduced.

DOUBLE DENSITY BOLT HOLES

Double-density gasket-clamping bolt holes are incorporated in Multi-CF fittings wherever space permits. Double-density holes have several advantages. They allow additional orientations between parts, where neither part has a rotatable flange. They compensate for the angular offsets which occurs with close couplers. They provide a possible work-around in the unlikely (but serious) situation of a damaged tapped hole. And they allow new bolting patterns (patterns other than the simple use of every other hole), which can generate very useful new assembly flexibilities.

EXTERNAL MOUNTING

ConFlat assemblies are frequently structurally mounted by placing auxiliary mounting brackets under the bolt heads of the gasket compression bolts. Unfortunately, varying loads on the brackets can cause varying loads on the bolts which will cause varying loads on the gasket, which may reduce seal reliability. Accordingly, additional tapped bolt holes have been provided, in some of the new parts, to allow external mounting by bolts not involved in gasket compression. Bakeout heaters may also be attached by means of these extra holes.

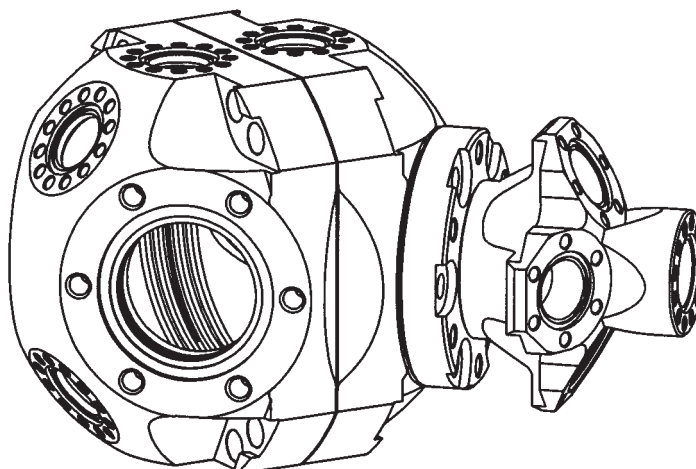
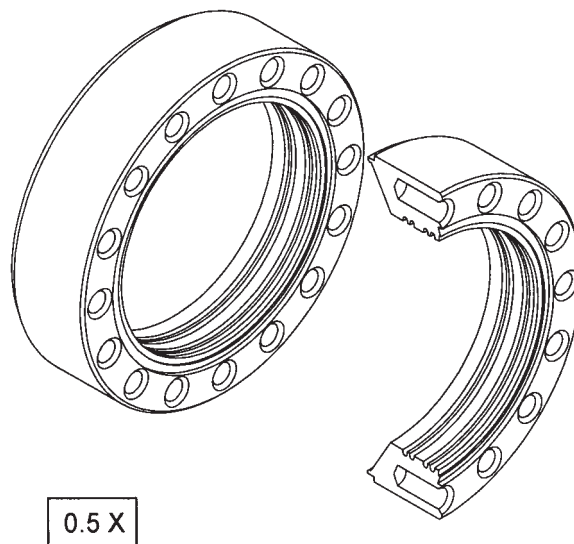

USER ISSUES

The Multi-CF project is still in an early incomplete stage. There are growing pains.

STOCKING CONSIDERATIONS

With a system like the Multi-CF fittings, it is easy to generate an exponentially growing number of possible stocking units. Hence value judgements must be made, and even then, maintaining parts in stock is a serious problem. New parts are being continuously added, and there is minimal experience as to which parts will have what level of demand. Thus out-of-stock problems are presently common. The situation will gradually improve.

At present no metric versions of the Multi-CF Fittings are available. A major problem has been the availability of metric bolts adequate to the task at hand (correctly-sized 12-point bolt heads, non-magnetic, good yield strength, silver plated, and correct lengths). A supplier has not yet been found. Suggestions are welcome. The silver plating and correct length issues can be handled locally.

CURRENT STATUS OF THE DESIGNS

At this point, the development of Multi-CF Fittings is only a partially completed undertaking. Two years ago, Kimball Physics was estimating the project as one-half complete. After two years of additional effort, it now appears about one-quarter complete. Numerous new fittings should be anticipated. There are several already-designed fittings, not included in this catalog due to the publication deadline. Additionally, several new concepts are either currently under development or just getting started.

The fittings are being designed by physicists (some would say inadequately supervised physicists who were supposed to be doing electron optics), who are themselves active users of the fittings. Thus, hopefully, the designs are coupled to real-world needs. Nonetheless, suggestions for improvements are actively solicited; frequently the best ideas come from users.

Custom fittings are available. However, manufacturing efficiency tends to force units to be produced in batches. Also, it is necessary to stay within the manufacturing limits of the CNC machines. Thus custom requests for small numbers may encounter delays while awaiting an appropriate manufacturing opportunity, and some may tend to be impractical, because of excessive setup or tooling costs.

Most parts are currently being manufactured from stainless steel 316, rather than stainless steel 304 which was used previously.

The Multi-CF Fittings are covered by patents 5,593,123, 5,625,947, 5,660,418, and 5,671,956; with additional work in process; and more being filed. In order to encourage standardization, some licenses are available at low cost.

