

4.7 BEAM PULSING OPTIONS cont.

4.7.3 PULSING with FIXED / VARIABLE DUAL GRID POWER SUPPLY

This method of pulsing usually involves a main EGPS Power Supply unit containing two grid supplies which is ordered at time of purchase. A TTL (transistor-transistor logic) pulse source is required, either a separate user-supplied pulse generator unit or a computer generated signal from a LabVIEW™ program. Typically, beam pulse widths from 2 μsec to DC with a 500 nsec rise/fall time and repetition rates up to 5 kHz maximum can be achieved with appropriate TTL inputs.

With this dual grid pulsing option, beam pulsing is accomplished using a TTL signal to control the two Grid supplies: one fixed and the other variable. The variable grid supply is the normal control grid supply which is varied by the user. The variable supply should be adjusted to a voltage which allows optimum beam current. The fixed grid supply is set at the factory to supply a single, fixed voltage which cuts off the electron beam. The block diagram (Fig. 4.7-6 shows the relation of the supplies; the fixed supply floats on the variable one.

A pulsing TTL (transistor-transistor-logic) signal rapidly switches the output voltage to the grid between the variable grid supply alone and the sum of the two supplies, which cuts off the beam. This pulses the beam on and off, as shown in Fig. 4.7-7 below. For example, if the fixed grid is -500 V and the variable grid supply is adjusted to -100 V, the grid element in the gun will be at -100 V when the TTL signal is +5 V, and the grid will be at -600 V when the TTL signal is 0 V.

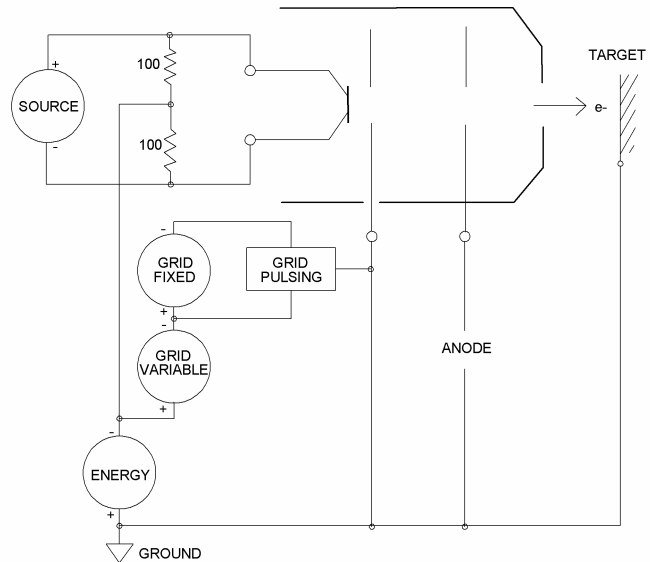

Fig. 4.7-6 Block Diagram for a typical Electron Gun with Fixed / Variable Grid Pulsing (Other supplies will vary with gun model)

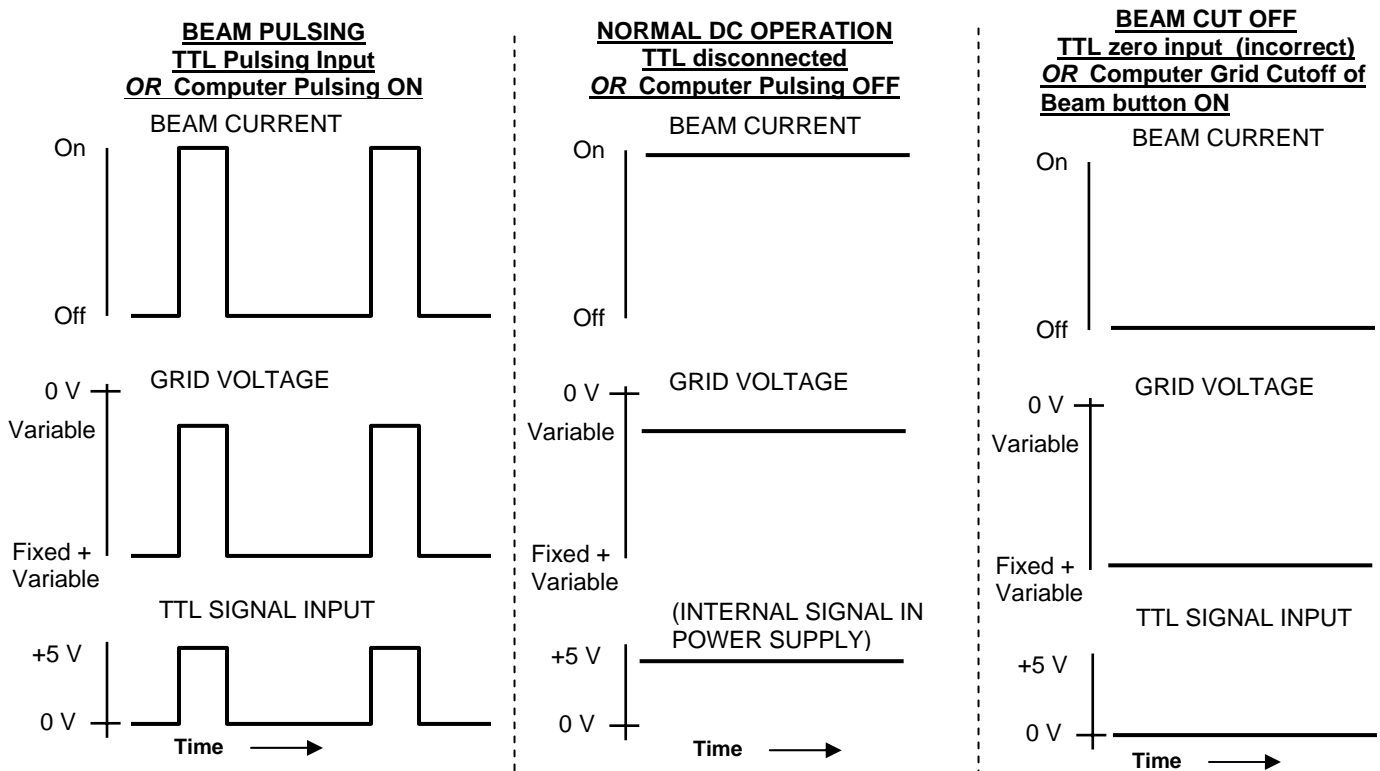

Fig. 4.7-7 Pulsing TTL Signal with either a TTL pulse generator or a LabVIEW™ program, alternating Fixed and Variable Grid Supplies, and Beam Current Response

4.7 BEAM PULSING OPTIONS cont.

PULSING with FIXED / VARIABLE DUAL GRID POWER SUPPLY cont.

The pulsing input signal can be provided by either an external user-supplied TTL pulse generator connected to the TTL IN BNC on the EGPS or by the LabVIEW™ program. A toggle switch labeled **TTL IN / COMPUTER** sets the pulse control mode.

Note that whenever there is a zero volt TTL signal, the beam will be cut-off by the fixed grid. Even if the cathode is on and the variable grid is adjusted to zero, the grid element will be at the fixed supply voltage (-500 V in the example) and there will be no beam.

When there is no TTL input, a pull-up resistor in the power supply will provide a +5 V signal, so that only the variable grid supply is enabled and the beam can be on. Thus for start-up and normal non-pulsed gun operation, the separate TTL generator must be disconnected or set for +5 V. Alternatively, if the default output on the generator is high (+5 V) when powered off, the generator could be connected but turned off for normal operation.

With the LabVIEW™ control program, the TTL pulsing signal is generated by the computer. The pulse toggle switch enables the high voltage fixed grid supply. The computer program has controls to set the pulsing signal rate, i.e. the frequency, pulse width and total number of pulses. These controls are interrelated, and there are some restrictions due to limitations of the power supply and computer counter.

With the program, the fixed grid supply is also used to temporarily stop the beam during normal operation when the GRID CUTOFF OF BEAM button is selected.

The amount of beam current emitted by the gun is a function of the source voltage (cathode temperature), energy, and grid voltage. See the Data Section for graphs of Beam Current vs Source and Beam Current vs Grid at various Energy values. For guns with a variable 1st anode supply, the beam also depends on the anode voltage. Precise beam current levels vary with operating conditions, so the user must determine appropriate grid voltages for the specific operating conditions employed.

CAUTION for HIGH CURRENT GUNS: Care should be used with average emission power over 100 W; excessive power could damage the gun or target. This power is calculated with the following equation:

$$V_{\text{electron energy}} \times I_{\text{avg emission}} = P_{\text{avg}}$$

For example, with continuous operation, 3 mA emission current at 80 keV yields 240 W of power. However with pulsing, 3 mA emission current that has a 1% duty cycle (pulsed on 1% of the time, so 0.03 mA avg current) at 80 keV yields only 2.4 W average power over time. Thus there could be a problem during set up, when the gun is not being pulsed.

DESCRIPTION OF POWER SUPPLY PULSING CONTROLS

Pulse Control Switch: A two position toggle switch labeled **TTL IN / COMPUTER** that selects the pulsing control mode.

TTL IN allows control by a separate user-supplied TTL pulse generator.

COMPUTER allows control by a LabVIEW™ program with a computer-generated pulse signal

Pulsing Input BNC: A BNC labeled **TTL IN** to receive a 0 to +5 VDC TTL from a user-supplied TTL pulse generator for optional grid pulsing. The TTL signal input controls the alternation between the variable and fixed grid supplies pulsing the beam on and off. A zero volt signal will cut off the electron beam. When the BNC is unterminated, an internal +5 V signal controls the grid supplies, allowing the beam to be on.



When the pulse switch is set to **COMPUTER**, this BNC is switched to output the computer TTL signal so that the pulse can be monitored or other user equipment can be synchronized to the pulsing.

Variable Grid Control/ Meter: A FlexPanel control labeled **GRID**. When selected, the encoder wheel voltage programs the variable Grid power supply. The value displayed is the variable Grid voltage, not the combination of the fixed and variable Grid supplies. Alternatively, computer controls can voltage program the variable Grid supply.

NOTE: With pulsing, the metering does not monitor the total output to the gun, only the variable grid voltage.

4.7 BEAM PULSING OPTIONS cont.

PULSING with DUAL GRID POWER SUPPLY: TTL OPERATION

	 <h1 style="margin: 0;">CAUTION</h1>
	<p>For gun start up or DC operation, the TTL pulse generator must be DISCONNECTED or the signal input must be a CONSTANT +5 V.</p>

1. Set up:
 - a. A separate, user-supplied 0 to +5 VDC TTL pulse generator is required.
 - b. Using a user-supplied coaxial cable, connect the TTL source to the BNC labeled **TTL IN** on the back of the EGPS.
 - c. Set the pulse control switch on the back of the EGPS to **TTL IN** (up, towards the BNC).
 - d. **CAUTION: For initial start-up and non-pulsing DC gun operation, the TTL source must be disconnected or provide constant +5V.** Depending on access, it may be easiest to connect the power supply end of the cable during power supply installation and just connect/disconnect the generator end later as needed.

2. For start up:
 - a. Disconnect the user-supplied TTL source. Alternatively, provide a **constant +5 V** signal input.
 - b. Follow the Normal Start Up Procedure, Section 4.2. to begin gun operation. Use instructions with the flex panel controls.
 - c. Using the **GRID** control (encoder wheel), adjust the variable Grid (G-1) supply to the voltage that produces optimum beam current and uniformity. Monitor this supply with the Grid Voltage metering.

3. **For beam pulsing:**
 - a. Reconnect and turn on the TTL source.
 - b. On the TTL generator, adjust the TTL input signal pulse rate, frequency and duty cycle as desired.

4. **For constant beam operation (DC):** Disconnect the user-supplied TTL source or provide a constant +5 V signal input.

CAUTION: If the TTL signal input is 0 V, the beam will be cut-off even if the cathode is on. This could cause the user to incorrectly increase the source current and burn out the cathode.

5. For shut down: Disconnect and turn off the TTL source.

H.V. WARNING (for guns with a High Voltage Fixed Grid power supply):

Whenever POWER and H.V. pushbuttons are pushed ON and the TTL is off, **the Grid pin and leads will be at the Fixed Grid High Voltage potential**, even if Energy is zero and the gun is not being pulsed with the TTL input. This is not a hazard when the gun is being operated normally (with the cables properly connected), but it could be dangerous during troubleshooting, especially for high power systems with a fixed grid in the kV range.

TTL input	Grid Voltage	Result
+5 V	Variable only	Beam ON
0 V	Fixed + Variable	Beam CUT-OFF

NOTE: With pulsing, the Emission Current metering may give a false reading, increasing as the pulse rate increases. Do not readjust the Source controls to compensate. To check the true emission, briefly turn off pulsing; the meter signal will return to the correct value immediately. The Grid Voltage meter reads only the variable grid supply, not the net output to the gun.

4.7 BEAM PULSING OPTIONS cont.

DESCRIPTION OF COMPUTER PULSING CONTROLS

Grid Control/ Meter: A digital input control that voltage programs the variable Grid power supply. This control does not affect the Fixed Grid which is used for beam cut off in pulsing, and the associated meter measures only the variable Grid output, not the total voltage applied to the Grid element in the gun.

Pulsing Switch: A two-position toggle switch labeled **PULSE ON / OFF** for the Dual Grid Pulsing option.

Pulse Frequency (Hz) and Pulse Width (μs): Digital controls that set the rate of the computer-generated (0, 5V) pulsing signal.

Pulse Frequency range: 0.1 to 5,000 Hz

Pulse Width range: 1 to 1,000,000 μs, recommended from 2 μs for smooth pulse.

of Pulses: A digital control that sets the number of pulses in a train. A positive integer produces a single train of pulses; a **0** produces continuous pulsing.

GRID CUTOFF OF BEAM Button: A yellow pushbutton used to stop the beam temporarily during normal operation. It enables the fixed Grid supply for beam cutoff and is the equivalent of pulsing the beam off once. This does not affect any of the other controls; the cathode will still be heated while the beam is cut-off. The button must be clicked off to resume operation.

Notes on Selecting Computer Pulsing Parameters

The pulsing rate controls are interrelated, and some combinations of values are not achievable.

Naturally, the combination of pulsing parameters chosen must be theoretically possible. For example, one could not have a 2 ms pulse at 1 kHz, because the pulses would overlap.

Some restrictions on the valid parameters are due to the way in which the computer generates the pulsing signal. In particular duty cycles close to zero or one are not achievable due to limitations of the computer DAQ board clocks and 24-bit counters. For example, although the values are within the normal ranges for pulse width and frequency, a 1 μs pulse at 1 Hz is not achievable because the longest cycle on the particular clock used is 0.84 sec.

The physical limitations in the power supply also limit the possible pulsing choices. Very fast continuous pulsing is not allowed, because the switching circuitry can overheat. Also, the response time of the circuitry limits the minimum possible length of a pulse.

Further restrictions in choosing pulsing parameters are the limits set in the program on the data ranges of the parameters. For example, the pulse width data range may be set to be 1 μs to 1000 μs. Some restrictions are due to limitations in the power supply, such as the 1 μs pulse lower limit due to the power supply circuitry. Other limits may be variable, such as the upper limit set to prevent excessive beam power. Kimball Physics can be consulted if a change in the data range of a parameter is desired.

The LabVIEW™ program will deliver an error message and a warning if the pulsing parameters cannot be achieved due to theoretical or computer constraints. In the error message box, click **CONTINUE**, (not STOP which would stop the whole program). Then enter new values on the panel.

Some valid combinations of pulsing parameters are given in the table below. Due to DAQ counter limitations, not all intermediate values will be possible. For example, a 22 μs pulse per second is not achievable, although a 20 μs or 30 μs pulse per second is possible.

CAUTION: Finally, as described on the next page, the overall power output must be considered so as to avoid damaging the gun or target.

Table 4.7-3 Some valid combinations for computer pulsing parameters:

Pulse Width	Pulse Frequency	
	minimum	max continuous
1 μs	15 Hz	5,000 Hz
2 μs	10 Hz	
10 μs	1.5 Hz	
20 μs	1 Hz	
100 μs	0.15 Hz	
1000 μs	0.1 Hz	500 Hz
1,000,000 μs	0.1 Hz	< 1 Hz

4 OPERATION

4.7 BEAM PULSING OPTIONS cont.

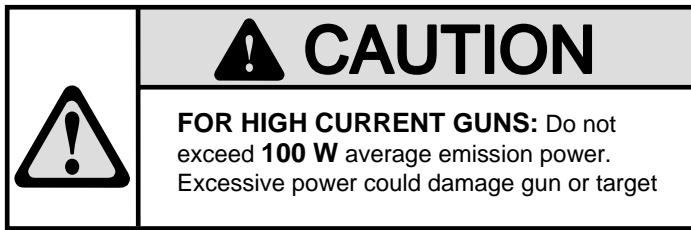

When pulsing, care should be taken that the pulsing duty cycle (pulse width x frequency) is kept low. As the duty cycle approaches 1 (or 100%), the gun approaches DC operation. For example, a 10 μs pulse at 1kHz frequency has a 1% duty cycle ($10 \times 10^{-6} / 10^{-3} = 0.01$ or 1%) which could effectively limit the overall power. However, a 500 μs pulse at 1 kHz has a 50% duty cycle, so the beam is on half the time

The amount of beam current emitted by the gun is a function of the source voltage (cathode temperature), energy, and grid voltage. See the Data Section for graphs of Beam Current vs Source and Beam Current vs Grid at various Energy values. For guns with a variable 1st anode supply, the beam also depends on the anode voltage. Precise beam current levels vary with operating conditions, so the user must determine appropriate grid voltages for the specific operating conditions employed.

CAUTION for HIGH CURRENT GUNS: Care should be used with average emission power over 100 W; excessive power could damage the gun or target. This power is calculated with the following equation:

$$V_{\text{electron energy}} \times I_{\text{avg emission}} = P_{\text{avg}}$$

For example, with continuous operation, 3 mA emission current at 80 keV yields 240 W of power. However with pulsing, 3 mA emission current that has a 1% duty cycle (pulsed on 1% of the time, so 0.03 mA avg current) at 80 keV yields only 2.4 W average power over time. Thus there could be a problem during set up, if the gun is not being pulsed.

PULSING with GRID POWER SUPPLY: COMPUTER OPERATION

- Follow the Normal Start Up Procedure, Section 4.3 to start and operate the gun.
 - Use a LabVIEW remote control program with a computer-generated 0 to +5 VDC pulsing signal.
 - Set the pulse control switch on the back of the EGPS to **COMPUTER** (down).
 - If desired a user-supplied oscilloscope can be connected to the BNC labeled **TTL IN** to observe the computer generated pulsing signal. Other user equipment can be synchronized to the pulsing by connecting to this BNC.

- On the computer, set the **PULSE** switch to **ON**
- Determine the appropriate Variable Grid setting:
 - Using the **GRID** control, adjust the Grid (variable grid supply) to the voltage that produces optimum beam current and uniformity. Monitor on the **GRID** meter.
- Set pulsing parameters:
 - Adjust the **Pulse Frequency (Hz)** and **Pulse Width (μs)** controls to give the desired pulse rate. Some combinations of pulse settings are not achievable. If a error message appears, click **CONTINUE** (not STOP) and enter new values. See notes and Table **4.7-3** above.
 - Set the desired **# of Pulses**.
 - Use a positive integer for a limited pulse train. For example, if **5** is entered, the beam will be pulsed on five times and then stop.
 - Use **0** for continuous pulsing. If **0** is entered, the pulsing will be continuous (i.e. there is no limit) until the **PULSE** switch is turned off.
 - With pulsing, the Emission Current meter will give averaged values and may fluctuate at very low rates, ex. 100 μA emission pulsed at 50% duty cycle will read 50 μA . The Grid Voltage meter reads only the variable grid supply, not the net output to the gun. (For systems with a Glassman H.V. Power supply, the Glassman current meter may not show any current if the average is too low.)
- To temporarily turn off pulsing and stop the beam
 - Click the yellow **GRID CUTOFF OF BEAM** button. This enables the fixed Grid supply and cuts off the beam, without affecting any other controls. The cathode will still be heated while the beam is cut-off.
- To turn off pulsing and go to continuous beam operation: **CAUTION: Before switching from pulsing to DC operation, ensure that the beam power will not be too high.**
 - If necessary, turn down the Energy or Source so that the power will not be too high when the beam is on continuously. (For systems with a Glassman H.V. Power supply, the current limit on the H.V. Supply also provides a safety factor limiting the beam power.)
 - Set the **PULSE** switch to **OFF**. Only the Variable Grid will be on, for beam control.
- To return to pulsing mode:
 - If used, click the **GRID CUTOFF OF BEAM** button again for off.
 - Set the **PULSE** switch to **ON**.

This completes the Beam Pulsing Instructions.