

8 7 6 5 4 3 2 1

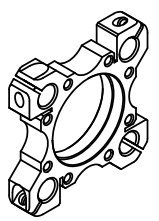

**ISOMETRIC VIEW
SCALE 2:1**

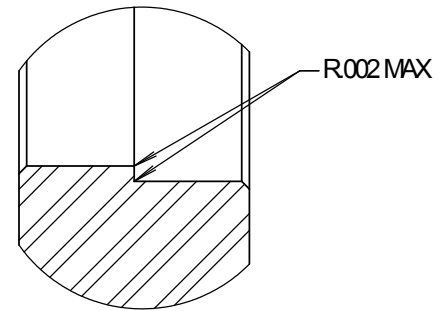
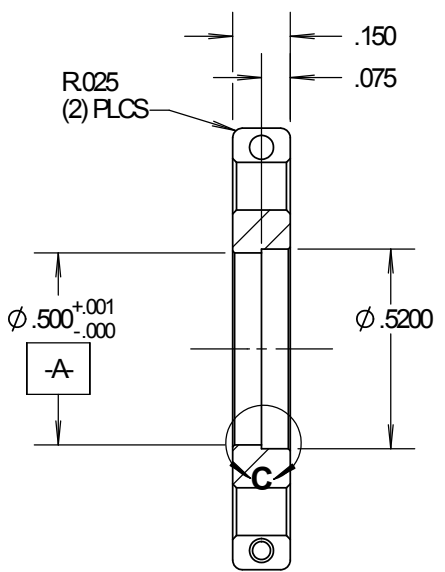

**DETAIL C
SCALE 8:1**

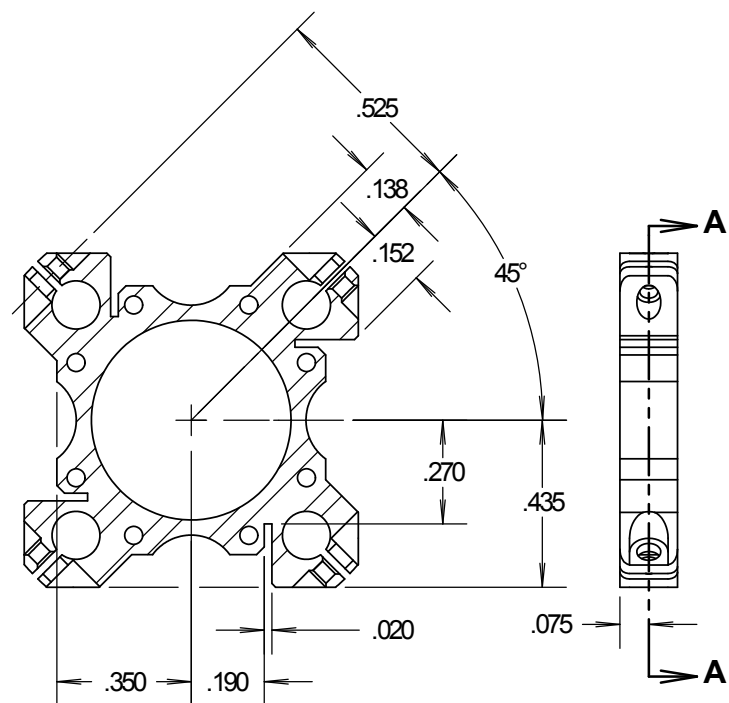

**SECTION A-A
(ALL DIMS TYP
(4) PLCS, 90° APART)**

**SECTION B-B
(VIEW ROTATED 45° CCW)**

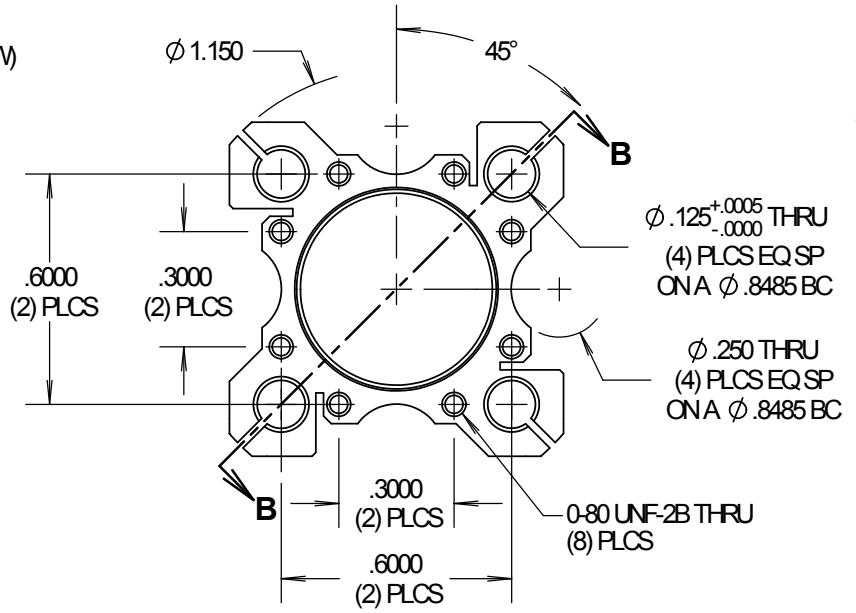

REV	REVISION DESCRIPTION	DATE	BY	CHK	QI	USED ON
A	INITIAL RELEASE	11/7/05	DJO			

THIS DOCUMENTATION IS THE PROPERTY OF KIMBALL PHYSICS, INC. AND IS PROVIDED TO THE RECEIVING PARTY (AND ITS EMPLOYEES HAVING A NEED TO KNOW) SOLELY FOR EVALUATION. IT MAY NOT BE USED BY THE RECEIVING PARTY FOR ANY OTHER PURPOSE OR DISCLOSED TO ANY THIRD PARTY WITHOUT THE WRITTEN CONSENT OF KIMBALL PHYSICS, INC.

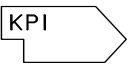
KIMBALL PHYSICS INC. 		
KIMBALL HILL RD., WILTON, NH 03086-9742 U.S.A. (603) 878-1616		
ELEMENT CLAMP SS-EC-4-150-500/520		
MATERIAL	SCALE	DWG. No.
316 SS	2:1	SS_EC_4_150_500_520-A
UNLESS OTHERWISE SPECIFIED DIMENSIONS ARE IN INCHES. DO NOT SCALE DRAWING.		SHEET 1 OF 1 MODEL No. 443EB01

8 7 6 5 4 3 2 1